

Model
ECC604T1

Version
V1.2 0324

Everything you need for
your Ceramic Cooktop
is in this User Manual

esatto

Welcome

Residentia Group

—

Head Office

165 Barkly Avenue
Burnley, Victoria
Australia 3121

—

ACN

600 546 656

—

Online

residentia.group
www.esatto.house
@esatto.house

—

Postage

PO Box 5177
Burnley, Victoria
Australia 3121

—

Telephone

1300 11 HELP (4357)

—

Email

support@residentia.group

Congratulations on purchasing your new cooktop. Esatto is proudly distributed in Australia by Residentia Group Pty Ltd.

Please refer to the warranty chapter at the rear of this manual for information regarding your product's parts and labour warranty, or visit us online at:

→ residentiagroup.com.au

Here at Residentia Group, we are customer obsessed and our Support Team are there to ensure you get the most out of your appliance. Should you want to learn more about your unit, and importantly, taking care of the appliance, our Support Team are here to help. You can use our online Support Centre at any time by visiting:

→ support.residentiagroup.com.au

Or you can contact us by dialing: 1300 11 HELP (4357)

It is important that you read through the following user manual thoroughly, in order to familiarise yourself with the installation and operation requirements of your appliance, and to ensure optimum performance.

Again, thank you for choosing an Esatto appliance and we look forward to being of service to you.

Kind Regards,
The Residentia Team

Customer Care

—

At Residentia Group, we strongly encourage the use of authentic spare parts to guarantee you the best results. When contacting our spare parts team through 1300 11 HELP, or by emailing parts@residentiagroup.com.au, please ensure that you have the model and serial numbers on hand, which are found on your appliances' rating plate.

Contents

Page 02
Welcome

Page 04
Safety Information

Page 06
Installation Instructions

Page 10
Your Esatto Cooktop

Page 11
Operating Instructions

Page 14
Care & Maintenance

Page 15
Troubleshooting

Page 17
Technical Specifications

Page 18
Purchase Details

Page 20
Warranty Information

Safety Information

Conditions of Use

This appliance is intended to be used in household and similar applications such as farm houses or by customers in serviced apartments, holiday apartments and other residential type of environments.

Installation

- Disconnect the appliance from the electricity supply before carrying out any work or maintenance on it.
- Connection to a good earth wiring system is essential and mandatory.
- Means for disconnection must be incorporated in the fixed wiring in accordance with the wiring rules.
- Alterations to the domestic wiring system must only be made by a qualified electrician.
- **WARNING:** Failure to follow this advice may result in electrical shock or death.
- Take care—panel edges are sharp.
- Failure to use caution could result in injury or cuts.
- Read these instructions carefully before installing or using this appliance.
- No combustible material or products should be placed on this appliance at any time.
- Please make this information available to the person responsible for installing the appliance as it could reduce your installation costs.
- In order to avoid a hazard, this appliance must be installed according to these instructions for installation.
- This appliance is to be properly installed and earthed only by a suitably qualified person.
- This appliance should be connected to a circuit which incorporates an isolating switch providing full disconnection from the power supply.
- Only use hob guards designed or recommended by the manufacturer. The use of inappropriate guards may result in an accident or cause damage to the appliance.
- Failure to install the appliance correctly could invalidate any warranty or liability claims.
- For further information regarding installation including a step-by-step guide, please refer to pages 06–09. For information regarding operating instructions, please refer to pages 11–13.

Operation & Maintenance

- Do not cook on a broken or cracked cooktop. If the cooktop surface is break or crack, switch the appliance off immediately at the mains power supply (wall switch) and contact a qualified technician.
- Ensure that before cleaning or maintenance, switch the cooktop off at the wall before beginning.
- **WARNING:** Failure to follow this advice may result in electrical shock or death.
- This cooktop appliance complies with electromagnetic safety standards.
- During use, accessible parts of this appliance will become hot enough to cause burns.
- Do not let your body, clothing or any item other than suitable cookware contact the ceramic glass until the surface is cool.
- Metallic objects such as knives, forks, spoons and lids should not be placed on the hob surface since they can get hot, and may become a safety hazard.
- Children less than 8 years of age shall be kept away unless continuously supervised.
- Handles of saucepans may be hot to touch. Check the saucepan handles do not overhang other cooking zones that are on. Keep handles out of reach of children.
- Failure to follow advice could result in burns and scalds.
- The razor-sharp blade of a cooktop scraper is exposed when the safety cover is retracted. Always operate with extreme care, and always ensure that you store the blade safely and out of reach of children.
- Failure to use caution could result in injury or cuts.
- Under no circumstances should you leave the appliance unattended when in use. Boilover causes smoking and greasy spillovers that may ignite.
- Never use your appliance as a work or storage surface.
- Never leave any objects or utensils on the appliance.
- Never use your appliance for heating up the home.
- After use, always turn off the cooking zones and the cooktop as described in this manual (i.e. by using the touch controls).
- Do not allow children to play with the appliance or sit, stand, or climb on it.

- Do not store items of interest to children in cabinets above the appliance. Children climbing on the cooktop could be seriously injured.
- Do not leave children alone or unattended in the area where the appliance is in use.
- Children or a person with a disability that limits their ability to use the appliance should have a responsible and competent person to instruct them in its use. The instructor should be satisfied that they can use the appliance without danger to themselves or their surroundings, before teaching how to use the cooktop.
- Do not repair or replace any part of the appliance unless specifically recommended in the manual. All other servicing should be done by a qualified technician.
- Do not use a steam cleaner to clean your cooktop.
- Do not place or drop heavy objects on your cooktop.
- Do not stand on your cooktop.
- Do not use pans with jagged edges or drag pans across the glass surface as this can scratch the glass.
- Do not use scourers or any other harsh abrasive cleaning agents to clean your cooktop, as these can scratch the ceramic glass.
- If the supply cord is damaged, it must be replaced by the manufacturer, its service agent or similarly qualified persons in order to avoid a hazard.
- This appliance is intended for a domestic household environment only. Commercial use of any kind is not and will not be covered under the manufacturer's warranty.
- **WARNING:** The appliance and its accessible parts become hot during use.
- Take care to avoid touching heating elements.
- Children less than 8 years of age shall be kept away unless continuously supervised.
- This appliance can be used by children aged from eight years and above, as well as persons with reduced physical, sensory or mental capabilities, or those with a lack of experience and knowledge if they have been given supervision or instruction concerning use of the appliance in a safe way and understand the hazards involved.
- Children should never not play with, inside or around the appliance. Cleaning and user maintenance should never be undertaken by children without supervision.
- **WARNING:** Unattended cooking on a hob with fat or oil can be dangerous and may result in fire. NEVER try to extinguish a fire with water, but switch off the appliance and then cover flame e.g. with a lid or a fire blanket.
- **WARNING:** Danger of fire—do not store items on the cooking surfaces.
- **WARNING:** If the surface is cracked, switch off the appliance to avoid the possibility of electric shock, for hob surfaces of glass-ceramic or similar material which protect live parts.
- Do not use a steam cleaner to clean the cooktop.
- The appliance is not intended to be operated by means of an external timer or separate remote-control system.
- **CAUTION:** The cooking process has to be supervised. Regardless of whether cooking for long or short periods, the cooking process must be supervised continuously.
- The bottom surface and the power cord of the hob should not be accessible after installation is complete.
- To arrange an authorised technician please contact our friendly support team at 1300 11 HELP (4357).

Disposal

- The appliance is labeled in compliance with the European directive 2012/19/EC for Waste Electrical & Electronic Equipment (WEEE). By ensuring that this appliance is disposed of correctly, you will have helped to prevent any possible damage to the environment and to human health, which otherwise may be caused if it were disposed of in the wrong way.
- The symbol on the product indicates that it may not be treated as normal household waste. It should be taken to a collection point for the recycling of electrical and electronic goods.
- This appliance requires specialist waste disposal. For further information regarding the treatment, recover and recycling of this product please contact your local council, your household waste disposal service, or the shop where you purchased it.
- For more detailed information about treatment, recovery and recycling of this product, please contact your local city office, your household waste disposal service or the shop where you purchased the product.

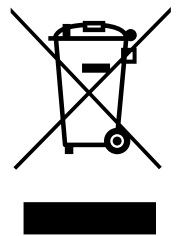

Installation Instructions

Preparing the Cut-Out

- Begin by cutting out the work surface according to the sizes shown in the diagram below.
- For the purpose of installation and use, ensure you leave a minimum of 5cm space around the cut out.
- Be sure the thickness of the work surface is at least 30mm. Please select a heat-resistant and insulated work surface material (Wood and similar fibrous or hygroscopic material should be avoided unless impregnated) to avoid the risk of electrical shock and larger deformation caused by the heat radiation from the hotplate. As shown below:

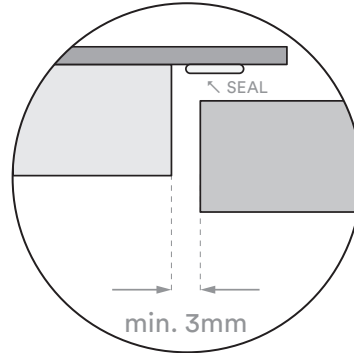

The safety distance between the sides of the cooktop and the inner surfaces of the worktop should be at least 3mm.

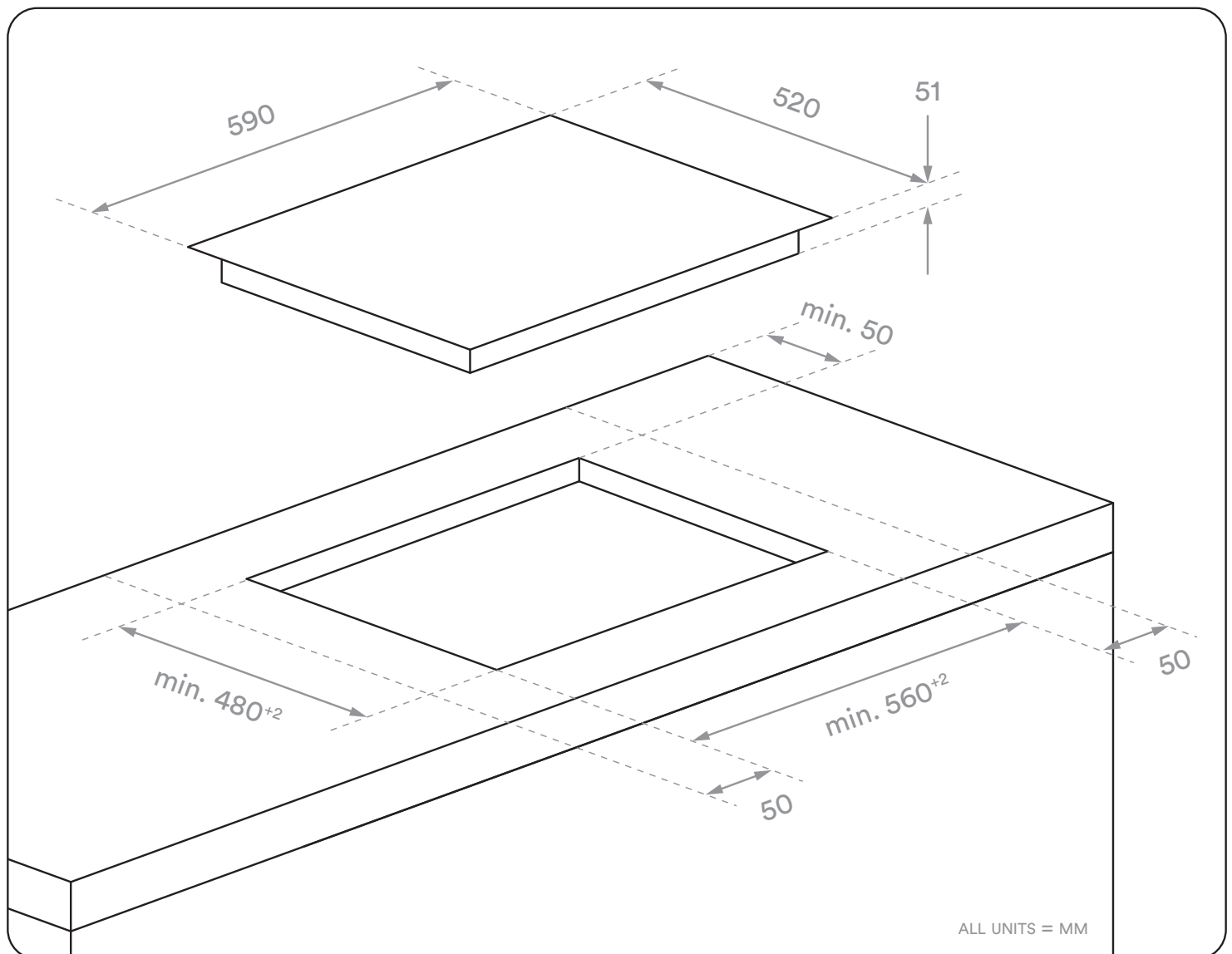

Preparing the Cut-Out (Continued)

- Under all circumstances, make sure the ceramic cooktop is well ventilated and the air inlet and outlet are not blocked. Ensure the ceramic cooktop is in good working state (as shown below).
- Please refer to your rangehood's user manual for exact minimum clearances from the top of the cooktop surface to your rangehood.

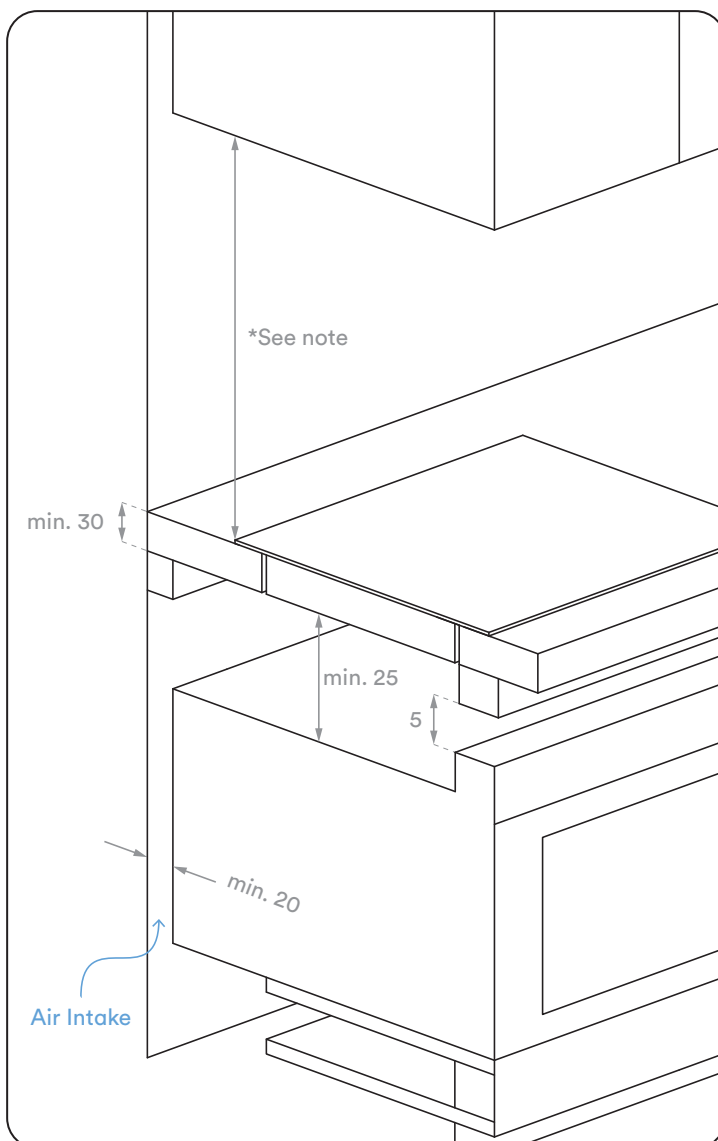

***Please Note:** Regarding adjacent walls, cupboards and protection for combustible materials: Always ensure that the appliance is installed in accordance with AS/NZS 5601.1, or AS/NZS 5601.2 with regard to clearances to combustible surfaces and materials, and clearances to rangehoods and exhaust fans.

Ensuring Adequate Ventilation

- Make sure the ceramic cooktop is well ventilated and that air inlet and outlet is not blocked. In order to avoid accidental touch with the overheating bottom of the cooktop, or getting unexpected electric shock during working, it is necessary to put a wooden insert, fixed by screws, at a minimum distance of 25mm from the bottom of the cooktop. Follow the requirements below.

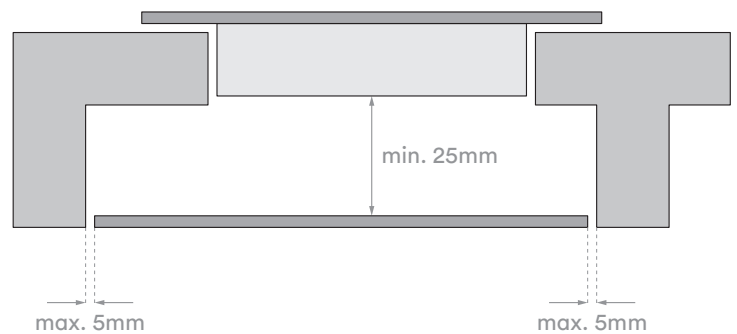

- **IMPORTANT:** There are ventilation holes around the outside of the hob. **YOU MUST** ensure that these holes are not blocked by the worktop when you are placing the hob into position.
- The glue that joins the material to the cabinetry must be resistant to temperatures of 150°C to avoid damage.
- The rear wall, adjacent and surrounding surfaces must therefore be able to withstand an temperature of 90°C.
- Ensure that the worktop is at least 30mm thick minimum.

Installation Safety Warnings

- The appliance must always be installed by an authorised technician or similarly qualified person. Please note that the manufacturer is not held responsible for any damage caused by defective placement or installation done by an unauthorised personnel.
- The ceramic cooktop should not be mounted to cooling equipment, dishwashers and rotary dryers.
- The ceramic cooktop shall be installed so that better heat radiation can be ensured to enhance its reliability.
- The wall and induced heating zone above the work surface must withstand high temperatures.
- To avoid any damage, the sandwich layer and adhesive must be resistant to heat.
- Do not use a steam cleaner to clean the cooktop.

Installation Instructions (Continued)

Applying the Fixing Brackets

- The unit should be placed on a stable, smooth surface (such as the packaging). Do not apply force onto the controls protruding from the hob. Fix the hob on the work surface by screwing in the four brackets on the bottom of hob after installation (see diagram A below).

IMPORTANT!

- When applying the brackets, ensure you adjust the brackets' position to suit your particular work surface's thickness. Under no circumstances are the brackets to touch with the inner surfaces of the worktop after installation (see diagram B below).

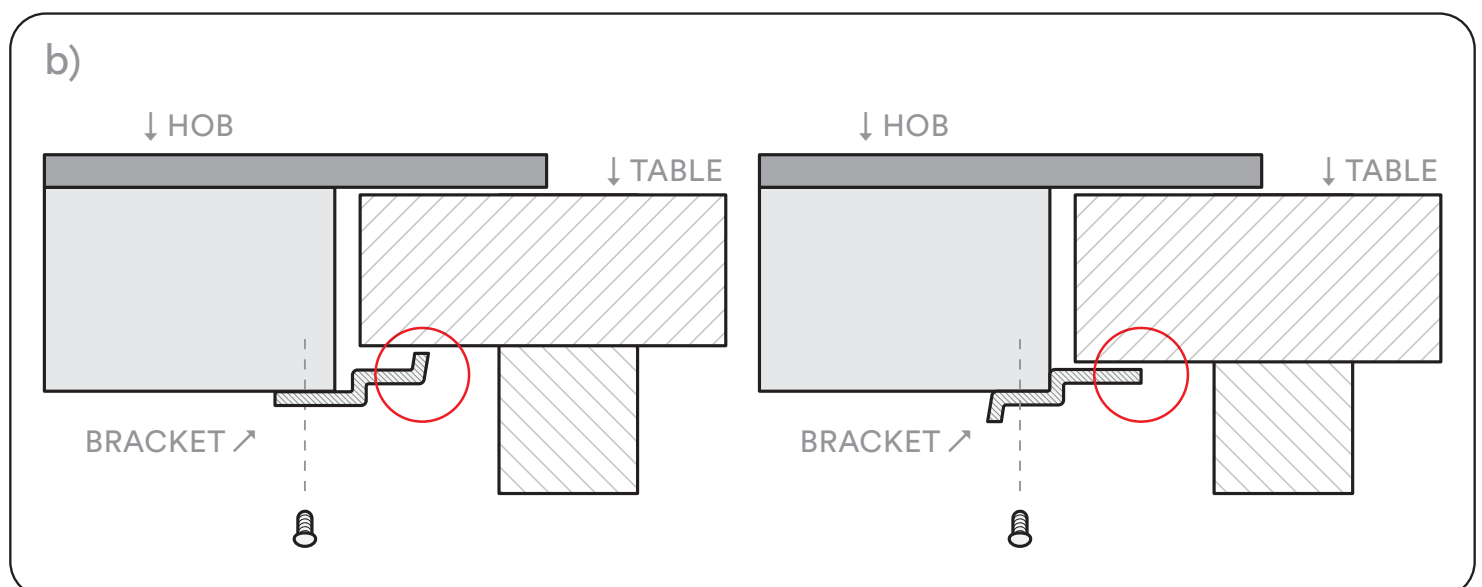
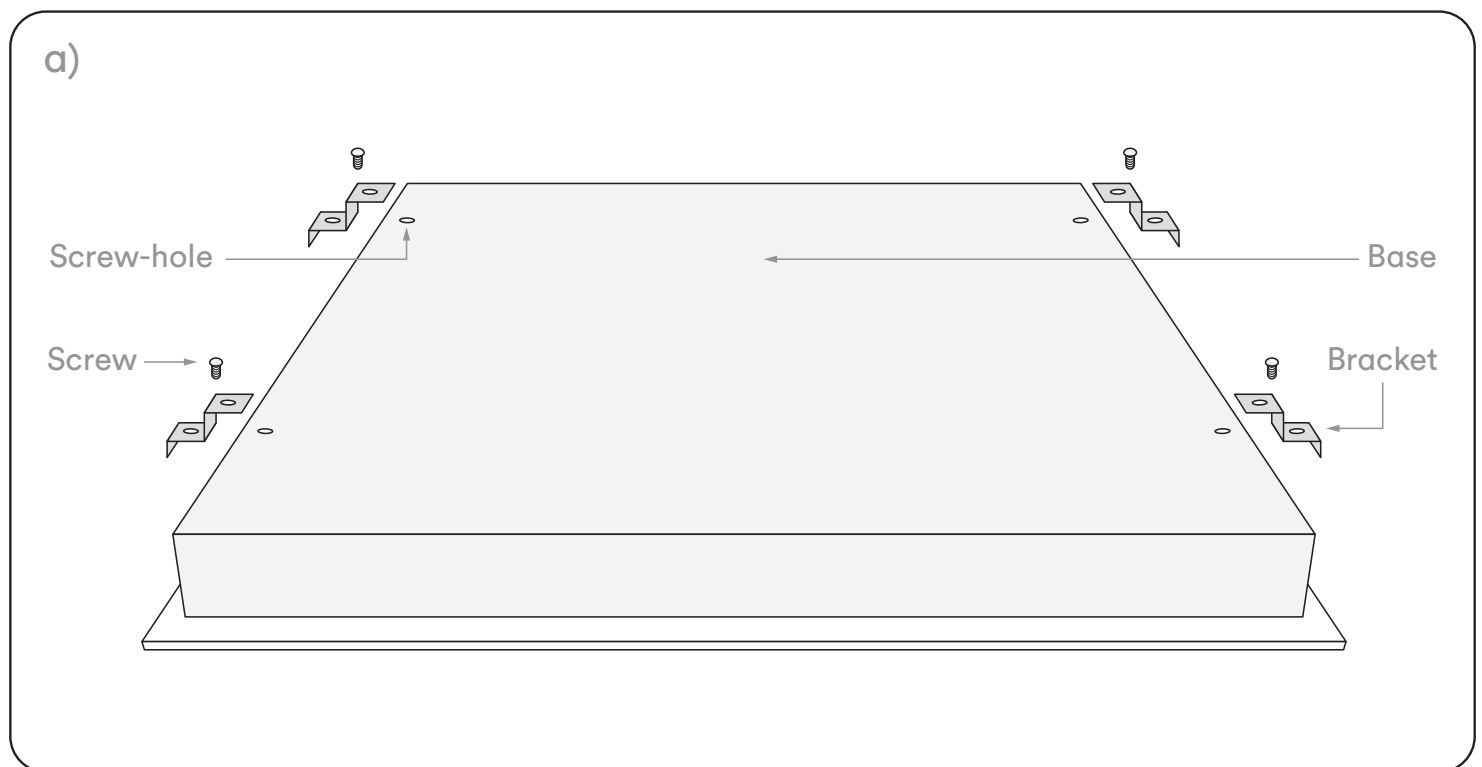

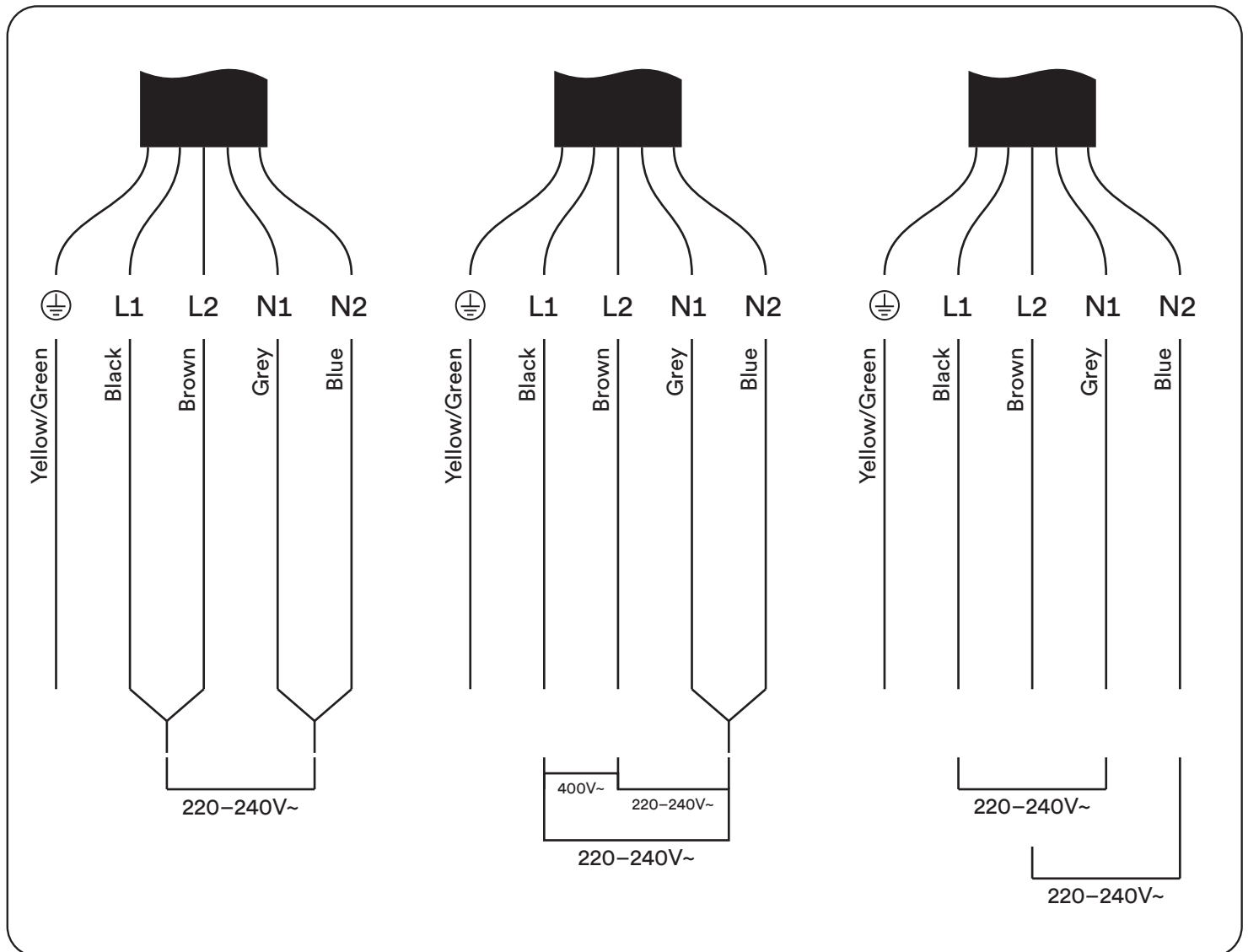

Connecting the Hob to the Mains Power Supply

- The power supply should be connected in compliance with the relevant standard, or a single-pole circuit breaker. The method of connection is shown above.
- If the cable is damaged or needs replacing, this should be done by an after-sales technician using the proper tools, so as to avoid any accidents.
- If the appliance is being connected directly to the mains supply, an omnipolar circuit breaker must be installed with a minimum gap of 3mm between the contacts.
- The installer must ensure that the correct electrical connection has been made and that it complies with safety regulations.
- The cable must not be bent or compressed.
- The cable must be checked regularly and only replaced by a properly qualified person.
- The bottom surface and the power cord of the hob should not be accessible after installation is complete.

Your Esatto Cooktop

Top View

Key

- 1. 1200W Zone Ø 165mm
- 2. 1800W Zone Ø 200mm
- 3. 1800W Zone Ø 200mm
- 4. 1200W Zone Ø 165mm
- 5. Cooktop Controls

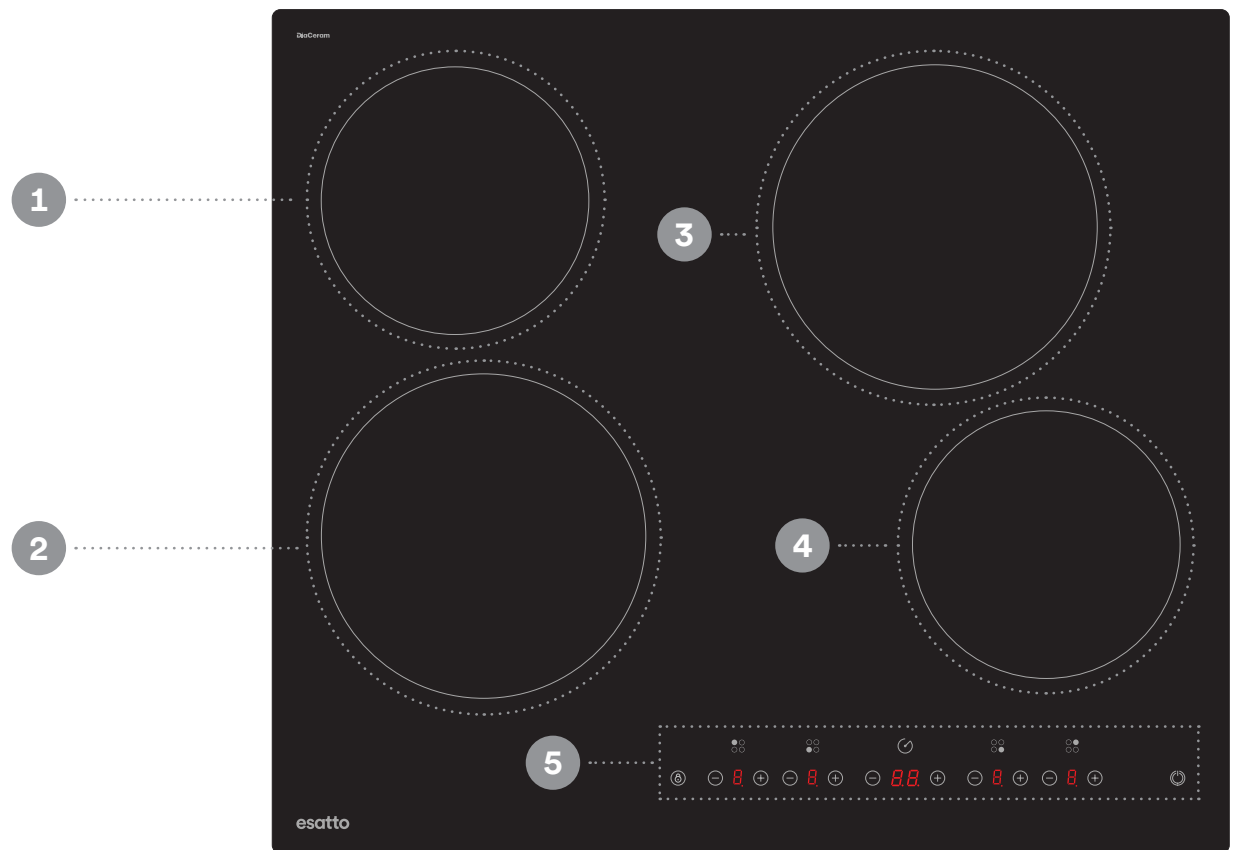

Controls

Key

- 1. Temperature Controls
- 2. Timer Function
- 3. Child Safety Lock
- 4. Power Button

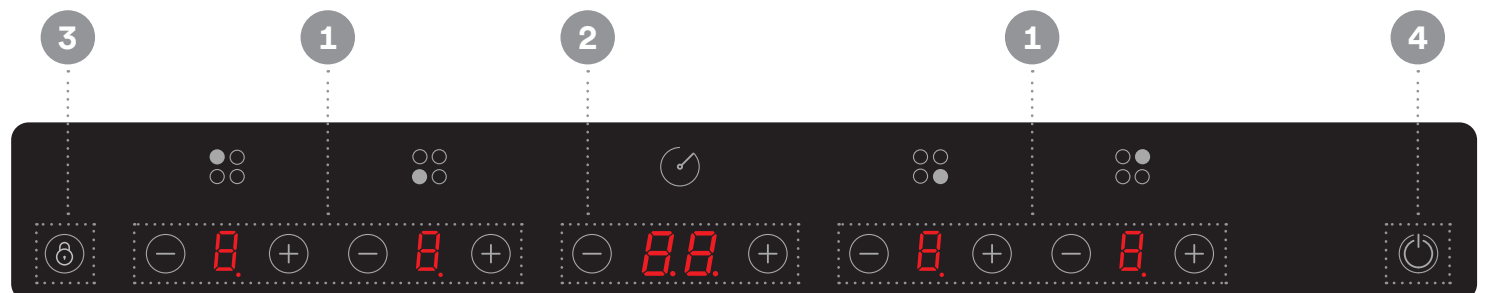

Operating Instructions

Using the Touch Controls

- Read this user manual carefully, taking special note of the 'Safety Information' chapter in particular.
- Ensure you remove any protective film that may still be on your cooktop surface after unpacking.
- The controls respond to touch, so you don't need any pressure. Use the pad of your finger, not the tip.
- You will hear a beep each time a touch is registered.
- Make sure the controls are always clean, dry, and that there is no object (e.g. a utensil or a cloth) on top. Even a thin film of water or food particles may make the controls unresponsive and difficult to operate.

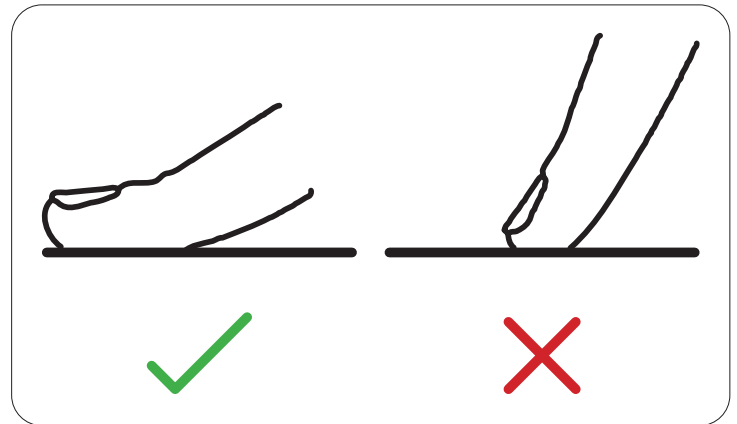

Choosing the Right Cookware

- Do not use cookware with jagged edges, coarse or uneven surfaces, chipped bottoms or a curved base.



- Make sure that the base of your pan is smooth, sits flat against the glass, and is the same size as the cooking zone. Always center your pan on the cooking zone.



- Always lift pans off the ceramic hob—do not slide them, as they may scratch the glass.



Operating Instructions (Continued)

Cooking With Your Ceramic Cooktop

Touch the Power button  to turn the cooktop on.

After the cooktop has been powered on, a buzzer tone will sound once, followed by the indicators lighting up for one second. This indicates that the ceramic cooktop is powered on, and has entered standby.



Place a suitable pan on the cooking zone you wish to use, referencing page 11.

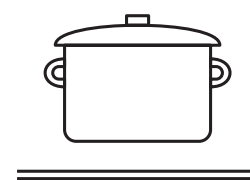

Make sure the bottom of the pan and the surface of the cooktop are clean and dry, that the cookware's diameter corresponds to the size of the zone, and that the surface of the cookware is smooth and flat, devoid of any jagged edges or a coarse or uneven surface.



Adjust the zone's heat setting by using the corresponding  and  buttons.

If you don't choose a heat setting within one minute, the cooktop will automatically switch off, and you will need to start again from the beginning. You can modify the heat settings at any time during cooking.



To turn off a cooking zone once cooking had completed, simply turn the temperature of the relevant zone to '0' using the relevant  and  buttons.

Alternatively you can hold both the  and  buttons for several seconds, which will achieve the same result.



'H' will show on your display to indicate that the cooking zone is hot to touch.

The cooktop will stop displaying 'H' once the surface has cooled down to a safe temperature, cool enough to touch. 'H' can also be used as an energy saving function if you want to continue heating cookware using the zone that is still hot.



To turn the cooktop off, press the power button  until the indicators are no longer lit.

Keep in mind that the cooktop's surface may be hot to the touch for some time. Safety precautions are strongly encouraged, particularly if children are present. After cooking is completed, avoid touching the surface of the cooktop, or leaving objects on top or nearby the cooktop.



Using the Timer Function

The Timer function can be used in two ways, either as a minute minder (kitchen timer), or as a way to automatically turn off cooking zones after a set period of time. The timer can be set up to 99 minutes.

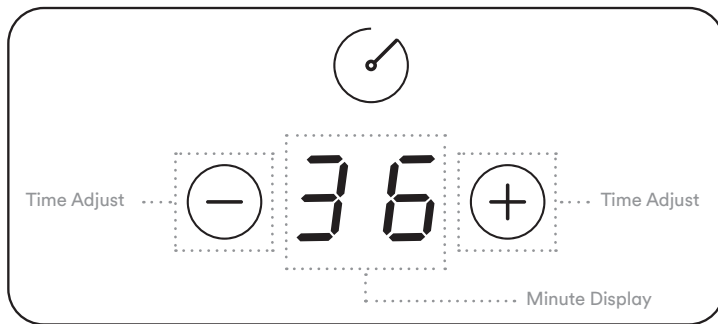

Using the Timer as a Minute Minder:

- To adjust the timer, use the clock's \ominus and \oplus buttons to set the timer. Each press of the \ominus and \oplus buttons increases or decreases the time by 1 minute, as shown by the minute display.
Holding either the \ominus or \oplus buttons while selecting a time will increase the units by 10 minutes, instead of 1.
Please note that the time set cannot exceed 99 minutes.
Hold the \ominus and \oplus buttons together to cancel the timer at any point in the process. The display will show '--'.
- When the time has been set, after a moment the minute display will flash for 5 seconds and begin to count down.
- Once the set time has elapsed, a tone will sound for 30 seconds, and the minute display will show '--'.

Using the Timer to Shut Down Cooking Zones:

- First touch the \ominus or \oplus buttons for the particular zone you would like to apply the timer.
- Follow step 1. of 'Using the Timer as a Minute Minder'.
A red decimal point will illuminate, indicating that the particular zone has had the timer selected.

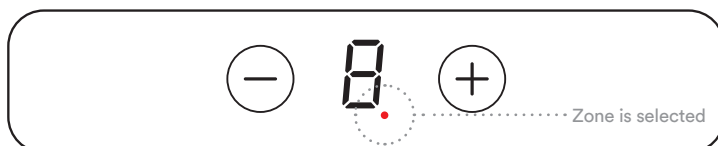

- When the timer has elapsed, the corresponding zone will switch off automatically. Other zones will continue to operate as normal.

Activating the Child Safety Lock

It is possible to lock the cooktop controls to prevent any unintended use. When the controls are locked, all of the controls will be disabled, except for the Power button.

To lock the controls:

- First touch the Child Safety Lock button Ⓢ , the display will show 'LO', indicating that the Child Safety Lock has been activated.
- To unlock the cooktop, ensure the cooktop is turned on. Next, touch and hold the Child Safety Lock button for several seconds and the cooktop will then unlock.

Auto-Shutdown Protection

Auto-Shutdown is a safety function designed to protect the cooktop. In the event that the cooktop is accidentally left running, the cooktop will automatically shutdown after a set period of time.

Despite this automatic safety feature, it is still strongly recommended to exercise awareness when cooking to avoid endangering yourself or your family.

Power Level:	1	2	3	4	5	6	7	8	9
Shut Down In:	8 ^{hr}	8 ^{hr}	8 ^{hr}	4 ^{hr}	4 ^{hr}	4 ^{hr}	2 ^{hr}	2 ^{hr}	2 ^{hr}

When a pot has been removed from the cooktop, the zone will stop heating immediately, and will automatically switch itself off after two minutes.

Over-Temperature Protection

Your appliance contains an in-built temperature sensor that monitors the temperature inside the cooktop. If an excessive build-up of heat is monitored, the cooktop will automatically stop operation.

Read on to learn how to clean and maintain your cooktop →

Care & Maintenance

Care and Cleaning Guide

Marks, Blemishes or Spots	Solution	Warning
<p>Everyday soiling on glass. (fingerprints, marks, stains left by food or non-sugary spillovers)</p>	<ol style="list-style-type: none"> 1. Switch the power to the cooktop off at the wall. 2. Apply a ceramic cooktop cleaner while the glass is still warm (but ensure it is not hot!) 3. Rinse and wipe dry with a clean cloth or paper towel. 4. Switch the power to the cooktop back on. 	<p>When the power to the cooktop is switched off, there will be no 'hot surface' indication but the cooking zone may still be hot! Take care.</p> <p>Heavy-duty scourers, some nylon scourers and harsh/abrasive cleaning agents may scratch the glass. Always read the label to check if your cleaner is suitable.</p> <p>Never leave cleaning residue on the cooktop as it may become a stain.</p>
<p>Boil-overs, melts, and hot sugary spills on the glass.</p>	<p>Remove these immediately with a fish slice, palette knife or scraper suitable for ceramic cooktops, but beware of hot cooktop surfaces:</p> <ol style="list-style-type: none"> 1. Switch the power to the cooktop off at the wall. 2. Hold the blade or utensil at a 30° angle and scrape the soiling or spill towards a cooler area. 3. Clean the soiling or spill up with a dish cloth or paper towel. 4. Follow steps 2 to 4 above. 	<p>Remove stains left by melts, sugary food or spillovers ASAP. If left to cool on the glass, they may be difficult to remove or even permanently damage the glass surface.</p> <p>Cut Hazard: When the safety cover is retracted, the blade in a scraper is razor-sharp. Use with extreme care and always store safely and out of reach of children.</p>
<p>Spillovers on the touch controls.</p>	<ol style="list-style-type: none"> 1. Switch the power to the cooktop off at the wall. 2. Soak up the spill 3. Quickly wipe the touch control area with a clean and damp sponge or cloth. 4. Wipe the area completely dry with a paper towel. 5. Switch the power to the cooktop back on. 	<p>The cooktop may beep and turn itself off, and the touch controls may not function while there is liquid on them.</p> <p>Make sure you wipe the touch control area dry before turning the cooktop back on.</p>

Troubleshooting

For Minor Faults

Problem	Possible Cause	Solution
The cooktop cannot be turned on.	No power is going to the cooktop.	<ul style="list-style-type: none"> Ensure the cooker is connected to the power, and is switched on. Check if there is a power outage in your home or area. If the problem persists contact our Support Team for guidance.
The touch controls won't respond, or are difficult to operate.	The controls may be locked, or there may be a slight film of water on the controls. You may be using the tip of your finger as opposed to the pad when touching controls.	<ul style="list-style-type: none"> Unlock the controls, see page 13. Make sure the touch controls are properly dry, and to use the pad of your finger rather than the tip.
The cooktop has been scratched.	Rough-edged cookware, or unsuitable cleaning products such as an abrasive scourer may have been used on the cooktop.	<ul style="list-style-type: none"> Use cookware with flat and smooth bases. See page 11.
Some of my cookware makes crackling or clicking noises.	This may be caused by the build of your cookware, as different layers of metals vibrate.	<ul style="list-style-type: none"> This is normal for cookware to make these noises, and does not indicate a fault.
The cooktop, or one of the zones has turned off unexpectedly, and a tone is sounding alongside an error code on the display.	This may be the result of a technical fault. To identify the fault code and its meaning, read the table on Fault Codes found on page 16.	<ul style="list-style-type: none"> Note down the error letters and numbers, switch off the power from the wall and contact our Support Team via 1300 11 4357 or by sending our team an email at support@residentiagroup.com.au

For Serious Faults:

- Some minor faults can be fixed by referring to the table on page 15, however if an emergency or serious fault occurs, immediately set all controls to their off positions and disconnect the power from the source.
- If a serious fault occurs, DO NOT attempt any repairs yourself, instead wait for a service agent to do so.
- For any assistance or to organize an authorised service agent contact our Support Team by calling 1300 11 4357, or by emailing support@residentiagroup.com.au.
- Please note that if a service agent is asked to attend whilst the product is under warranty and finds that the problem is not the result of an appliance fault, then you may be liable for the cost of the call out charge.
- The appliance must be accessible for the service agent to perform any necessary repair. If your appliance is installed in such a way that a service agent is concerned that damage will be caused to the appliance or your kitchen, then they will not complete a repair.
- Please refer to the Warranty Information to learn more.

Troubleshooting (Continued)

Cooktop Fault Codes & Solutions

Fault Code	Possible Cause	Solution
'E0'	Zero error.	<ul style="list-style-type: none"> Reinsert the connection between the display board and the power board, or replace the power board if it is damaged.
'E1'	The cooktop's temperature sensor has failed due to short-circuiting.	<ul style="list-style-type: none"> Check and repair the circuit connection, or replace the ceramic temperature sensor. To avoid any damage to the appliance, risk of bodily harm or property damage, do not attempt to carry out any repairs yourself, instead wait for a service agent.
'E2'	The cooktop's temperature sensor has failed due to short-circuiting.	
'E7'	The cooktop's temperature sensor has failed	
'E1'	Extremely high temperatures have been detected by the ceramic plate sensor.	<ul style="list-style-type: none"> Please allow the cooktop to fully cool down before restarting it. However if the problem persists, please call our Support Team by dialing 1300 11 4357 or email at support@residentiagroup.com.au
'E3'	An NTC temperature sensor has likely failed due to open circuiting.	<ul style="list-style-type: none"> The display board needs to be replaced. Take note of the fault code and please call our Support Team by dialing 1300 11 4357 or email us at support@residentiagroup.com.au to organise an authorised service agent.
'E4'	An NTC temperature sensor has likely failed due to short circuiting.	
'EL'	The supply voltage is below the rated supply voltage recommended.	<ul style="list-style-type: none"> Please ensure that the power supply is as recommended, see page 17 for details. Only once power is adjusted accordingly can you turn the cooktop back on.
'EH'	The supply voltage is exceeding the rated supply voltage recommended.	
'EU'	A communication error has occurred.	<ul style="list-style-type: none"> Reinsert the connection between the display board and the power board, or replace the power board if it is damaged.

Note: These fault codes will only appear if an abnormality or fault occurs. In such an occurrence, the cooktop will enter a protective state and display one of the relevant fault codes as listed above. Do not ignore these codes if they appear.

Technical Specifications

Specifications Chart

Model	ECC604T1
Rated Voltage	220–240V~ / 380–415V~
Rated Frequency	50 or 60Hz
Total Power	5500–6600W
Cooktop Zone A *	1200W, Ø 165mm
Cooktop Zone B *	1800W, Ø 200mm
Cooktop Zone C *	1800W, Ø 200mm
Cooktop Zone D *	1200W, Ø 165mm
Weight (Net / Gross)	7.2kg / 10.5kg
Dimensions (W × D × H)	590 × 520 × 51mm

Cooktop Zone Key *

↳

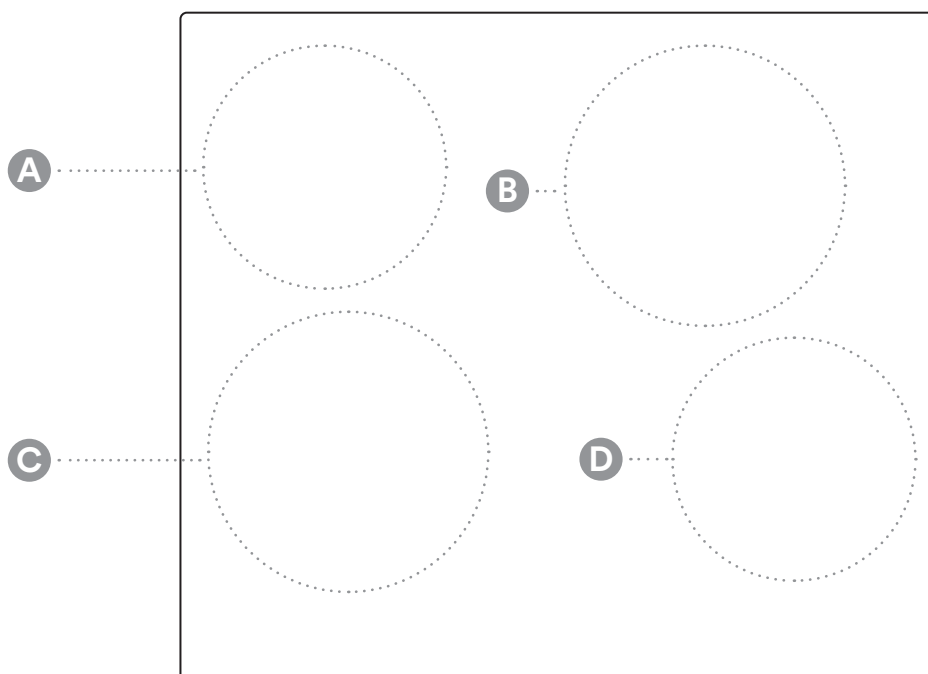

Need Help?

If you're feeling stuck and need assistance, you can speak to our Support Team by calling 1300 11 4357, or simply reach out by emailing support@residentiagroup.com.au

Attach Your Receipt Here



Purchase Details

For future reference, please record the following information which can be found on the rating plate and the date of purchase which can be found on your sales invoice.

STORE DETAILS

STORE NAME | _____

ADDRESS | _____

TELEPHONE | _____ PURCHASE DATE | _____

PRODUCT DETAILS

MODEL NO. | _____

SERIAL NO. | _____

Warranty (Australia)

WARRANTY TERMS AND CONDITIONS COOKTOPS

This document sets out the terms and conditions of the product warranties for Residentia Group Appliances. It is an important document. Please keep it with your proof of purchase documents in a safe place for future reference should you require service for your Appliance.

1. **IN THIS WARRANTY**
 - (a) 'acceptable quality' as referred to in clause 10 of this warranty has the same meaning referred to in the ACL;
 - (b) 'ACL' means Trade Practices Amendment (Australian Consumer Law) Act (No.2) 2010;
 - (c) 'Appliance' means any Residentia Group product purchased by you accompanied by this document;
 - (d) 'ASR' means Residentia Group authorised service representative;
 - (e) 'Residentia Group' means Residentia Group Pty Ltd of 165 Barkly Ave, Burnley VIC 3121, ACN 600 546 656 in respect of Appliances purchased in Australia;
 - (f) 'major failure' as referred to in clause 10 of this warranty has the same meaning referred to in the ACL and includes a situation when an Appliance cannot be repaired or it is uneconomic for Residentia Group, at its discretion, to repair an Appliance during the Warranty Period;
 - (g) 'Warranty Period' means:
 - (i) where the Appliance is used for personal, domestic or household use (i.e. normal single family use) as set out in the instruction manual, the Appliance is warranted against manufacturing defects for 24 months, following the date of original purchase of the Appliance;
 - (h) 'you' means the purchaser of the Appliance not having purchased the Appliance for re-sale, and 'your' has a corresponding meaning.
2. This warranty only applies to Appliances purchased and used in Australia and is in addition to (and does not exclude, restrict, or modify in any way) any non-excludable statutory warranties in Australia.
3. During the Warranty Period Residentia Group or its ASR will, at no extra charge if your Appliance is readily accessible for service, without special equipment and subject to these terms and conditions, repair or replace any parts which it considers to be defective. Residentia Group or its ASR may use remanufactured parts to repair your Appliance. You agree that any replaced Appliances or parts become the property of Residentia Group. This warranty does not apply to light globes, batteries, filters, seals or similar perishable parts.
4. Parts and Appliances not supplied by Residentia Group are not covered by this warranty.

-
5. You will bear the cost of transportation, travel and delivery of the Appliance to and from Residentia Group or its ASR. If you reside outside of the service area, you will bear the cost of:
- travel of an authorised representative;
 - transportation and delivery of the Appliance to and from Residentia Group or its ASR, in all instances, unless the Appliance is transported by Residentia Group or its ASR, the Appliance is transported at the owner's cost and risk while in transit to and from Residentia Group or its ASR.
6. Proof of purchase is required before you can make a claim under this warranty.
7. You may not make a claim under this warranty unless the defect claimed is due to faulty or defective parts or workmanship. Residentia Group is not liable in the following situations (which are not exhaustive):
- the Appliance is damaged by:
 - accident
 - misuse or abuse, including failure to properly maintain or service
 - normal wear and tear
 - power surges, electrical storm damage or incorrect power supply
 - incomplete or improper installation
 - incorrect, improper or inappropriate operation
 - insect or vermin infestation
 - failure to comply with any additional instructions supplied with the Appliance;
 - the Appliance is modified without authority from Residentia Group in writing;
 - the Appliance's serial number or warranty seal has been removed or defaced;
 - the Appliance was serviced or repaired by anyone other than Residentia Group, an authorised repairer or ASR.
8. This warranty, the contract to which it relates and the relationship between you and Residentia Group are governed by the law applicable where the Appliance was purchased.
9. To the extent permitted by law, Residentia Group excludes all warranties and liabilities (other than as contained in this document) including liability for any loss or damage whether direct or indirect arising from your purchase, use or non use of the Appliance.
10. For Appliances and services provided by Residentia Group in Australia, the Appliances come with a guarantee by Residentia Group that cannot be excluded under the Australian Consumer Law. You are entitled to a replacement or refund for a major failure and for compensation for any other reasonably foreseeable loss or damage. You are also entitled to have the Appliance repaired or replaced if the Appliance fails to be of acceptable quality and the failure does not amount to a major failure. The benefits to you given by this warranty are in addition to your other rights and remedies under a law in relation to the Appliances or services to which the warranty relates.
11. At all times during the Warranty Period, Residentia Group shall, at its discretion, determine whether repair, replacement or refund will apply if an Appliance has a valid warranty claim applicable to it.
12. Missing parts are not covered by warranty. Residentia Group reserves the right to assess each request for missing parts in a case by case basis. Any parts that are not reported missing in the first week after purchase will not provide free of charge.
13. To enquire about claiming under this warranty, please follow these steps:
- carefully check the operating instructions, user manual and the terms of this warranty;
 - have the model and serial number of the Appliance available;
 - have the proof of purchase (e.g. an invoice) available;
 - telephone the numbers shown below.
14. You accept that if you make a warranty claim, Residentia Group and its ASR may exchange information in relation to you to enable Residentia Group to meet its obligations under this warranty.

IMPORTANT

Before calling for service, please ensure that the steps in point 13 have been followed.

CONTACT SERVICE

- 1300 11 HELP (4357)
- support@residentiagroup.com.au

The Australian Consumer Law requires the inclusion of the following statement with this warranty:

Our goods come with guarantees that cannot be excluded under the Australian Consumer Law. You are entitled to a replacement or refund for a major failure and for compensation for any other reasonably foreseeable loss or damage. You are also entitled to have the goods repaired or replaced if the goods fail to be of acceptable quality and the failure does not amount to a major failure.

Warranty (New Zealand)

NEW ZEALAND WARRANTY TERMS & CONDITIONS COOKTOPS

To help care for your investment, be sure to register your appliance online. Registration will help you if you need to arrange service in the future, and serves as a record of your purchase—including critical information like model number and serial number – that you can refer to at any time. Simply visit the below website, or ask your retailer for help: www.esatto.house/nz/registration

WARRANTY

These products are covered by a warranty for a period of 24 months from the date of purchase, subject to the following conditions*. The warranty covers rectification free of charge of any fault arising from defective materials or components, or faulty workmanship or assembly.

* The conditions above mentioned are:

1. That the purchaser carefully follows all instructions packed with the product;
2. That the purchaser and/or installer carefully follows the installation instructions provided and complies with electrical wiring regulations, gas and/or plumbing codes;
3. That the purchaser carefully follows instructions provided in the owner's handbook relating to the proper use and care of the product and does not use the product for any purpose other than the domestic use for which it has been designed;
4. Commercial use of the product for professional or industrial purposes will void this warranty.;
5. That the product was purchased and installed in New Zealand;
6. That this warranty does not extend to:
 - a) optional glass lids for hobs apart from claims which relate to mechanical or physical damage thereof at the date of purchase;
 - b) 'consumable' parts such as light bulbs or filters;
 - c) damage to ceramic glass caused by liquid or solid spill-overs, lack of maintenance, or impact;
 - d) damage to surface coatings caused by cleaning or maintenance using products not recommended by the owner's handbook;

- e) defects caused by normal wear and tear, accident, negligence, alteration, misuse or incorrect installations;
 - f) a product dismantled, repaired or serviced by any serviceman other than an authorised service agent;
 - g) a product not in possession of the original purchaser;
 - h) damage caused by power outages or surges
 - i) damage caused by pests (eg. rats, cockroaches etc.)
7. That if the product is a freestanding microwave oven or small appliance it must be returned to the dealer/ retailer for servicing. These products, unless stated otherwise, have a 12 month warranty from original date of purchase with 24 months on the microwave magnetron; Waste disposers have a 12 month warranty.
 8. The provision of service under this warranty is limited by a 25km boundary from the retailer where the product was purchased except for microwaves. Such travelling outside of these limits will incur commercial cost to be paid by you, regulated by the number of kilometres travelled beyond the 25km limit (50km return trip). Microwaves are to be delivered to the nearest authorised service agent by the customer.

Please refer to your user manual for any further conditions that may apply to your specific model.

Nothing herein contained shall be construed in any way as excluding or limiting your rights under the Consumer Guarantees Acts 1993.

For Service please visit www.applico.co.nz/service or contact the dealer/retailer from whom you purchased the product from or call the 0800 number listed below. If you are unable to establish the date of purchase, or the fault is not covered by this warranty, or if the product is found to be in working order, you will be required to bear all service call charges.

Registration of this warranty constitutes acceptance of the terms and conditions of this warranty.

Should you require any assistance, please call Customer Services on 0800 763 448.

Distributed by Applico Ltd. www.applico.co.nz July 2019

After registering your appliance online, we recommend you fill out the below information for your reference and keep this warranty card in a safe place.



E2447

esatto
everything
you need



A RESIDENTIA
GROUP INITIATIVE