

**Esatto**  
by airvolution

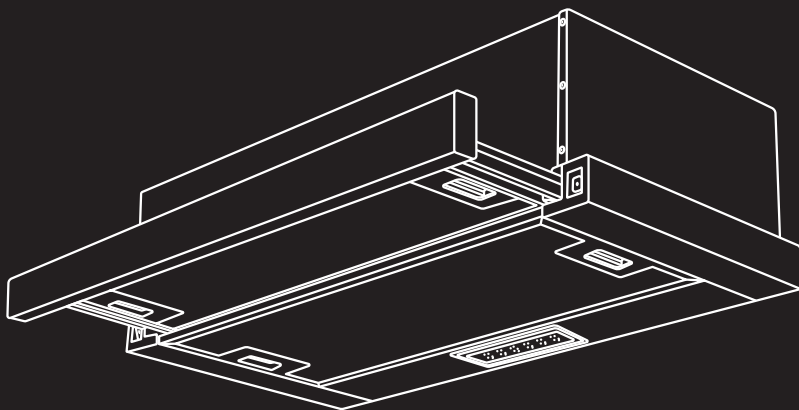

**USER MANUAL**

**Slide-out Rangehood**  
60cm

**MODEL: ESL60D2S**



## CONTENTS

PAGE	SECTION
4	Welcome Section
5	General Safety
7	Product Overview
8	Installation
12	Operating Instructions
13	FAQ
14	Other Useful Information
16	Purchase Details
17	Warranty

# A Residentia Group Initiative

---

## Residentia Group

—  
Head Office  
165 Barkly Avenue  
Burnley, Victoria  
Australia 3121

—  
ACN.  
600 546 656

—  
Online.  
residentia.group

Dear Customer,

Congratulations on purchasing your new rangehood. The Esatto brand is proudly distributed within Australia by Residentia Group Pty Ltd.

Please refer to the warranty card at the rear of this manual for information regarding your product's parts and labour warranty, or visit us online at [www.residentia.group](http://www.residentia.group)

At Residentia Group, we are customer obsessed and our Support Team are there to ensure you get the most out of your appliance. Should you want to learn more about optional accessories (such as carbon filters) or most importantly taking care of your rangehood when cleaning, our Support Team are here to help.

You can use our online Support Centre at anytime by visiting <http://support.residentiagroup.com.au>, or you can contact us via telephone by dialling 1300 11 HELP (4357).

It is important that you read through the following use and care manual thoroughly to familiarise yourself with the installation and operation requirements of your appliance to ensure optimum performance.

Again, thank you for choosing an Esatto appliance and we look forward to being of service to you.

Kind Regards,  
The Esatto & Residentia Teams

---

Postage.  
PO Box 5177  
Burnley, Victoria  
Australia 3121

---

Telephone.  
1300 11 4357  
Email.  
[support@residentiagroup.com.au](mailto:support@residentiagroup.com.au)

## GENERAL SAFETY

---

Read this manual thoroughly before first use, even if you are familiar with this type of product. The safety precautions enclosed herein reduce the risk of fire, electric shock and injury when correctly adhered to. Keep the manual in a safe place for future reference, along with the completed warranty card and purchase receipt. If applicable, pass these instructions on to the next owner of the appliance. Always follow basic safety precautions and accident prevention measures when using an electrical appliance, including the following:

### Important Installation Advice

**WARNING:** All electrical work associated with the installation of this rangehood must be carried out by a licensed electrician.

**WARNING:** This rangehood must be installed by a suitably qualified person in strict accordance with all instructions in this manual.

**Cables:** Do not allow electrical fittings or cables to come into contact with areas on the associated equipment (cooktop or stove) that get hot.

**Air discharge:** The exhaust air must not be discharged into a flue which is used for exhausting fumes from appliances burning gas or other fuels.

**External air evacuation:** Make sure to follow your local laws that apply to external air evacuation when installing and using the rangehood.

### Electrical safety and cord handling

**Voltage and frequency:** Before plugging the unit into an appropriate electrical outlet, make sure your outlet voltage and circuit frequency correspond to the voltage stated on the appliance rating label.

**Power cord:** Check the cord regularly for damage. Do not use the appliance if the cord, or any other part of the appliance, has been damaged.

**Damaged cord:** A damaged cord must be replaced by the manufacturer or a similarly qualified person in order to avoid a hazard.

**Disconnect:** Before cleaning the rangehood, make sure to switch it off and unplug it from the electrical supply. Do not disconnect the appliance with wet hands. Grip by the plug, do not pull by the cord when disconnecting.

### Usage conditions and restrictions

**Domestic use only:** This rangehood is designed for indoor domestic use only. It can be built into a standard kitchen cabinet or housing unit following the installation instructions in this manual.

**Intended purpose:** Only use this rangehood for its intended purpose, in its intended environment and as described in this manual. Any other use may cause fire, electric shock or injury.

**Use common sense:** These instructions are not intended to cover every possible condition and situation. As with any electrical household appliance, common sense and caution are therefore always recommended when installing, operating and maintaining the equipment.

## General Safety Continued

Usage restriction: This rangehood is not intended for use by persons (including children) with reduced physical, sensory or mental capabilities, or lack of experience and knowledge, unless they have been given supervision or instruction concerning use of the appliance by a person responsible for their safety.

Children: Supervise young children to ensure they do not play with the appliance. Close supervision is necessary when any appliance is used by or near children.

No timer: The appliance is not intended to be operated by means of an external timer or separate remote control system.

**CAUTION:** Take care when the rangehood is operating simultaneously with an open fireplace or burner that depend on air from the environment and are supplied by other than electrical energy, as the rangehood removes air from the environment which a burner or fireplace needs for combustion.

Ventilation: The rangehood removes air from the environment during use. Always provide adequate ventilation for safe operation of the rangehood. This is particularly important when the rangehood is used at the same time as flued heaters burning gas or other fuels.

**CAUTION:** No open flame cooking: Do not use an open flame for cooking underneath this rangehood. Open flames can damage the filters and present a fire hazard.

Unattended: Do not leave the rangehood unattended during use.

After use: Make sure to switch off the rangehood after use and before cleaning.

**CAUTION:** Do not touch the light bulbs after the appliance has been used as they may be hot. Let them cool down before cleaning and maintenance.

**WARNING:** Fire Risk! Clean your rangehood regularly as instructed in this manual. There is a fire risk if cleaning is not carried out in accordance with the instructions.

Cleaning: Do not use steam cleaning equipment for cleaning any part of the rangehood.

Filters: Do not check the status of the filters while the rangehood is in use.

Damage: Do not use the rangehood if any part, including the supply cord, has been damaged, is faulty or does not work properly. Only have it repaired by an authorised service centre. Incorrect repair could expose you to the risk of electric shock, fire or injury. Prolonged use of the unit in such conditions could cause fire or electrocution. In case of damage, contact our after sales support line for advice.

Liability: We assume no liability for any eventual damages caused by incorrect installation, misuse of the product or noncompliance with these instructions.

## PRODUCT OVERVIEW



---







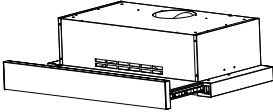

### KEY

- 1 Rangehood housing
  - 2 Slide-out Front Fascia Rail
  - 3 Inner Aluminium Grease Filter
  - 4 Outer Aluminium Grease Filter
  - 5 On/Off Switch
  - 6 Fan Speed Switch
  - 7 2W LED Lamp
-

# INSTALLATION

## Installation Kit

The installation kit contains the following parts:

Part ID	Description	Illustration	Qty
1	Rangehood		1
2	Rear-underside support mounting bracket		1
3	Screws (ST4 x 30mm)		6
4	Screws (ST4 x 8mm)		2
5	Wall Plugs (8mm)		6
6	Flat Washers		6
7	Front Vent Cover —If external ducting selected		1
8	Flu Outlet Adapter		1



## Unpacking

- This product has been packaged to protect it against transportation damage. Unpack the appliance and remove all packaging materials from around the rangehood. Keep all packaging materials until you have made sure your new rangehood is undamaged and in good working order. The carton is recyclable. Whenever possible, reuse the carton and recycle it when disposing of the packaging materials.
- Plastic wrapping can be a suffocation hazard for babies and young children, so ensure all packaging materials are out of their reach, and dispose of them safely.

## Important installation advice

### WARNING!

- All electrical work associated with the installation of this rangehood must be carried out by a licensed electrician.
- This rangehood must be correctly installed by a suitably qualified person in strict accordance with all applicable rules and regulations and following the instructions in this manual.
- Do not try to install the rangehood yourself; doing so will expose you to danger and void the warranty. Improper installation, adjustment, alteration or service can cause injury or damage. We decline any responsibility for injury or damage, to persons or property, as a result of improper installation.

### External Outdoor Ducting Mode:

This product has been supplied with "ducting mode" only.

Before installation, please confirm the adjuster pointing on the ducting mode.

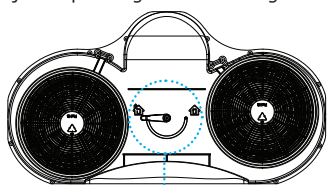

Fig. 1

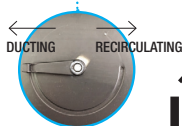

Fig. 2

1. Remove the aluminium grease filters (Fig 6. on page 10) from the underside of the rangehood. Turn the switch in the centre of the motor housing to "External Outside Ducting" position (Fig. 1)

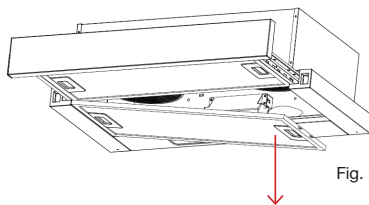
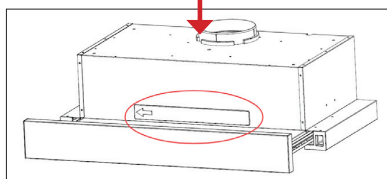
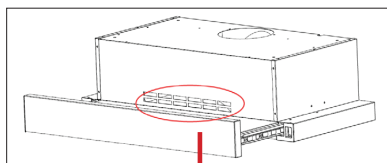

Fig. 3

2. Clip in the plastic Front Vent Cover (part ID 7, installation kit) over the vent holes on the front of the rangehood.



3. Using the screws provided, install the Flu Outlet Adaptor (Part ID 8, Installation kit) to the top of the rangehood
4. Install the ducting pipe (not supplied) to the outlet on the top of the rangehood and vent to external air. It is recommended that the ducting pipe is 120mm in diameter.

### Installation height:

For optimum performance, it is recommended that the rangehood be installed at a height of between 650-750mm from the cooking surface. See Fig. 5 for detailed AS/NZS minimum distance requirements.

### Rear-mounting to the wall

- Using a spirit level, mark a horizontal line on the wall where the rangehood base will be, observing all necessary clearances (Fig. 5). Check the required clearances in your cooktop/stove manual and, should they be greater than those specified in Fig. 5, make sure to observe them.

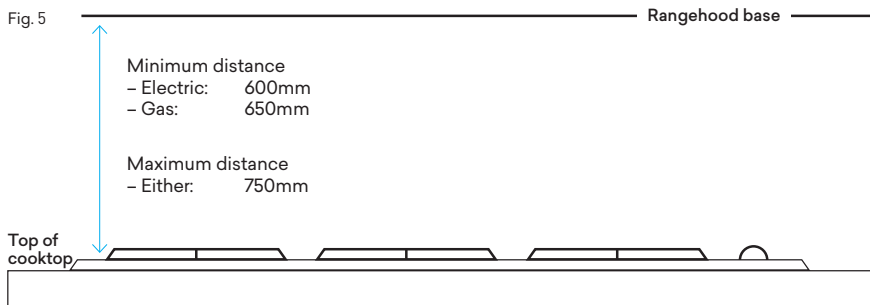

- Drill 4 holes of  $\varnothing 8\text{mm}$  on the wall, as illustrated below (Fig. 6).
- Hammer the wall plugs into the holes, then insert two ST4x30mm screws into the lower wall plugs. Tighten the screws, but leave a 2mm gap so that you can hang the rangehood on the screws in the keyhole slots.
- Hang the hood to the wall screws, and make sure the hood is in balance and positioned correctly.
- Take away the Aluminum Filters, mark and drill another 2 holes of  $\varnothing 8\text{mm}$  on the wall. (Safety Screw Holes)
- Take back the hood and hammer the wall plugs, hang the hood again and fix the hood with two ST4x30mm screws.

**WARNING:** Failure to install the screws or fixing device in accordance with these instructions may result in electrical hazards!

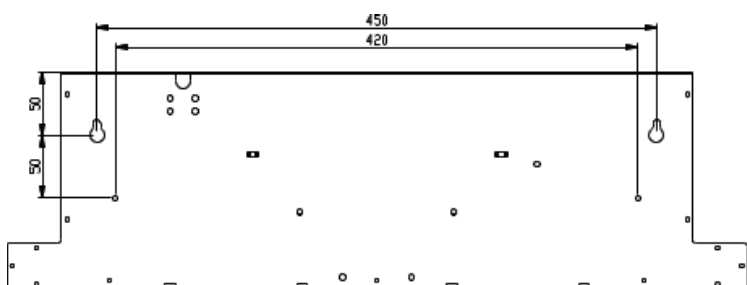
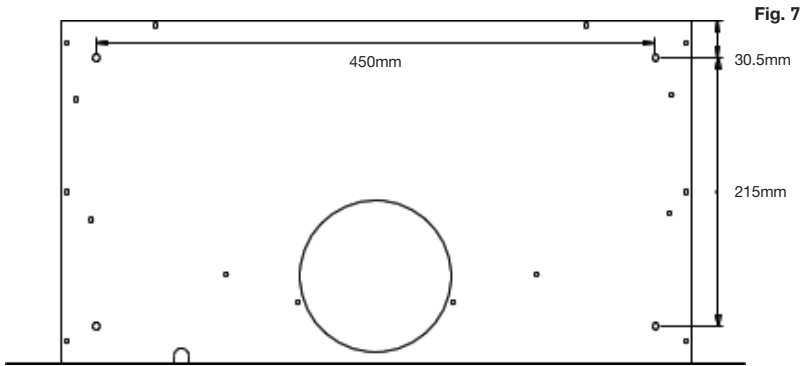

Fig. 6

### Top-mounting in a cabinet

- Determine where in the top cabinet you want to install the rangehood, then drill 4 holes of  $\text{Ø}4\text{mm}$  at the bottom of the hanging board of your cabinet (Fig. 7).



- Install the rangehood onto the bottom of the cupboard and secure it in place with four ST4x30mm screws (Fig 8).
- If there is a space between the wall and the rear of the rangehood, install the rear-underside support mounting bracket (Part ID 2, Installation kit) using the two ST4x8mm screws.

**WARNING:** Failure to install the screws or fixing device in accordance with these instructions may result in electrical hazards!

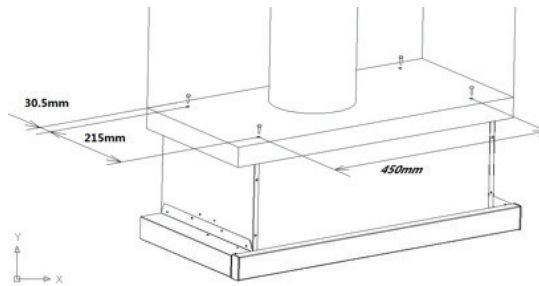

## OPERATING INSTRUCTIONS



This switch is to turn the rangehood either on or off.

- I Turns the rangehood ON
- O Turns the rangehood OFF



This button toggles between fan speed high, fan speed low and off setting

- = Turns on the fan motors to high speed for maximum extraction
- O Turns off the fan motors for no extraction, the fan motors are off
- Turns on the fan motors to low speed minimum extraction

### NOTE:

- The rangehood will only operate once the slide-out rail is pulled outwards towards the kitchen.
- Close the front panel and the rangehood will stop working.
- The next time the front panel is pulled back out, the rangehood will start working at the previously set level.

## FAQ

### Troubleshooting guide

If you experience problems with your rangehood, or it appears not to be operating correctly, check in the list below for answers to frequently asked questions. If none of the solutions offered help you solve your problem, please contact our after sales support line for advice.

**Do not attempt to repair the appliance yourself!**

Problem	Possible Cause	Solution
The extractor fan ceases to function.	There is no electrical current in the network.	Check with other appliances that your electricity supply is in working order.
There is insufficient suction power.	Wrong suction speed has been selected, or the air outlet is blocked.	Select suction speed " II " if speed " I " was selected.
		The charcoal filter needs to be replaced. The charcoal filter needs to be replaced if food smells start to become noticeable within your kitchen.
		If the rangehood is installed to vent outside, check that the ducting and outlets are free of blockages.
		Make sure your kitchen is adequately vented to allow the entry of fresh air.
The rangehood has switched off during operation.	The safety cut-out device has been tripped.	Turn off the rangehood and wait for the device to reset.
		If the rangehood has been installed below the height levels indicated in the "Installation" section, the motor will cut out frequently, which may damage the rangehood.
The bulbs do not light up.	The bulbs are loose, or burnt out.	Tighten the bulbs, or replace them, if necessary.

## OTHER USEFUL INFORMATION

### Cleaning and maintenance

#### CAUTION!

- Before cleaning the rangehood or carrying out maintenance, make sure the operation and light switches are set to the "0" position and the rangehood is disconnected from the power supply.
- It is important to clean the filters regularly as oil and food residues can become a fire hazard.
- Never use a steam cleaner to clean any part of the rangehood.

### Cleaning the rangehood exterior

Wipe the exterior surface of the rangehood regularly using a soft cloth moistened with a household solvent such as methylated spirits, or with a sponge dampened with water and a little non-abrasive liquid detergent.

### Cleaning the grease filters

The aluminium mesh filters must be cleaned regularly in order to prevent a fire hazard. Regular cleaning also ensures better efficiency, as grease and grime can impede the airflow. We recommend cleaning them at least every two months.

- Push in the plastic opening latch and take the filters out of their frames (Fig. 9).

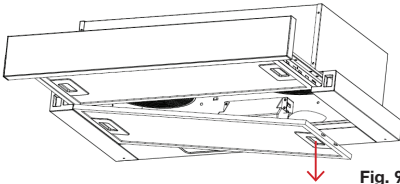

Fig. 9

- Wash the filters thoroughly in warm, soapy water, leaving them to soak for best results. Rinse with warm water and leave to dry.

**NOTE:** The aluminum panels may slightly change colour after several washes. This is not a fault and no cause for concern. It does not affect performance and does not warrant replacement of these parts.

### Replacing LED Lamp

If the LED lamp needs replacing, proceed as follows

- Unplug the power of rangehood for safety
- Open the filters
- Remove the lamp from inside the housing
- Unplug the plastic plug cover
- Replace the broken lamp and assemble the connector, followed by plug cover
- Push the lamp back to the casing from outside
- Reinstall the filters
- Plug the rangehood back in

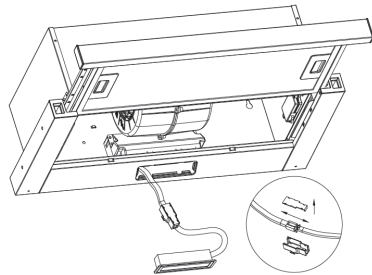

### Spare parts

Our after sales support centre stocks a wide range of spare parts for the ESL60D2S Rangehood. To purchase a part, call the centre on 1300 11 43 57 or email us at support@residentiagroup.com.au

• Blower	• Charcoal filter	• Connection box and bar
• Ducting	• Switch	• Slider
• Lamp & lamp holder	• Motor	• Outlet
• Reflector	• Filter (aluminium mesh, inner and outer)	

### Specifications

Rated voltage/frequency	AC 220-240V50Hz
Dimensions (H×W×D)	176mm × 599mm × 278mm
Extended depth	278-472mm
Height of front panel	40mm
Weight	8.5kg
Motor power	2 × 100W
Lamp power	1 × 2W
Total input power	202W
Housing	Painted white with stainless steel trim
Filters	2 Aluminium mesh filters

This product complies with AS/NZS 60335.2.31:2004+A1:2006 +A2:2007+A3:2009+A4:2010 for electrical safety, and with EN 55014-1:2006+A1:2009+A2:2011 for electromagnetic compatibility.

### Responsible disposal

At the end of their working life, do not throw any of these appliances out with your household rubbish. Electrical and electronic products contain substances that can have a detrimental effect on the environment and human health if disposed of inappropriately. Observe any local regulations regarding the disposal of electrical consumer goods and dispose of it appropriately for recycling. Contact your local authorities for advice on recycling facilities in your area.

## PURCHASE DETAILS

For your records, please record details of your purchase below and staple your receipt onto this page.

→ Receipt



### Store details

Store name | \_\_\_\_\_

Address | \_\_\_\_\_

Telephone | \_\_\_\_\_

Purchase date | \_\_\_\_\_

### Product details

Model no. | \_\_\_\_\_

Serial no.\* | \_\_\_\_\_

\* Note. Your serial number can be found on the inside of the rangehood, underneath the grease filter.



# WARRANTY

---

## **Warranty terms and conditions Cooking appliances (rangehoods)**

This document sets out the terms and conditions of the product warranties for Residentia Group Appliances. It is an important document. Please keep it with your proof of purchase documents in a safe place for future reference should you require service for your Appliance.

1. In this warranty
  - (a) 'acceptable quality' as referred to in clause 10 of this warranty has the same meaning referred to in the ACL;
  - (b) 'ACL' means Trade Practices Amendment (Australian Consumer Law) Act (No.2) 2010;
  - (c) 'Appliance' means any Residentia Group product purchased by you accompanied by this document;
  - (d) 'ASR' means Residentia Group authorised service representative;
  - (e) 'Residentia Group' means Residentia Group Pty Ltd of 118 Campbell St Collingwood Victoria 3083, ACN 600 546 656 in respect of Appliances purchased in Australia;
  - (f) 'major failure' as referred to in clause 10 of this warranty has the same meaning referred to in the ACL and includes a situation when an Appliance cannot be repaired or it is uneconomic for Residentia Group, at its discretion, to repair an Appliance during the Warranty Period;
  - (g) 'Warranty Period' means:
    - (i) where the Appliance is used for personal, domestic or household use (i.e. normal single family use) as set out in the instruction manual, the Appliance is warranted against manufacturing defects for 24 months, following the date of original purchase of the Appliance;
  - (h) 'you' means the purchaser of the Appliance not having purchased the Appliance for re-sale, and 'your' has a corresponding meaning.
2. This warranty only applies to Appliances purchased and used in Australia and is in addition to (and does not exclude, restrict, or modify in any way) any non-excludable statutory warranties in Australia.
3. During the Warranty Period Residentia Group or its ASR will, at no extra charge if your Appliance is readily accessible for service, without special equipment and subject to these terms and conditions, repair or replace any parts which it considers to be defective. Residentia Group or its ASR may use remanufactured parts to repair your Appliance. You agree that any replaced Appliances or parts become the property of Residentia Group. This warranty does not apply to light globes, batteries, filters or similar perishable parts.
4. Parts and Appliances not supplied by Residentia Group are not covered by this warranty.

## WARRANTY CONTINUED

5. You will bear the cost of transportation, travel and delivery of the Appliance to and from Residentia Group or its ASR. If you reside outside of the service area, you will bear the cost of:
  - (a) travel of an authorised representative;
  - (b) transportation and delivery of the Appliance to and from Residentia Group or its ASR, in all instances, unless the Appliance is transported by Residentia Group or its ASR, the Appliance is transported at the owner's cost and risk while in transit to and from Residentia Group or its ASR.
6. Proof of purchase is required before you can make a claim under this warranty.
7. You may not make a claim under this warranty unless the defect claimed is due to faulty or defective parts or workmanship. Residentia Group is not liable in the following situations (which are not exhaustive):
  - (a) the Appliance is damaged by:
    - (i) accident
    - (ii) misuse or abuse, including failure to properly maintain or service
    - (iii) normal wear and tear
    - (iv) power surges, electrical storm damage or incorrect power supply
    - (v) incomplete or improper installation
    - (vi) incorrect, improper or inappropriate operation
    - (vii) insect or vermin infestation
    - (viii) failure to comply with any additional instructions supplied with the Appliance;
  - (b) the Appliance is modified without authority from Residentia Group in writing;
  - (c) the Appliance's serial number or warranty seal has been removed or defaced;
  - (d) the Appliance was serviced or repaired by anyone other than Residentia Group, an authorised repairer or ASR.
8. This warranty, the contract to which it relates and the relationship between you and Residentia Group are governed by the law applicable where the Appliance was purchased.
9. To the extent permitted by law, Residentia Group excludes all warranties and liabilities (other than as contained in this document) including liability for any loss or damage whether direct or indirect arising from your purchase, use or non use of the Appliance.
10. For Appliances and services provided by Residentia Group in Australia, the Appliances come with a guarantee by Residentia Group that cannot be excluded under the Australian Consumer Law. You are entitled to a replacement or refund for a major failure and for compensation for any other reasonably foreseeable loss or damage. You are also entitled to have the Appliance repaired or replaced if the Appliance fails to be of acceptable quality and the failure does not amount to a major failure. The benefits to you given by this warranty are in addition to your other rights and remedies under a law in relation to the Appliances or services to which the warranty relates.
11. At all times during the Warranty Period, Residentia Group shall, at its discretion, determine whether repair, replacement or refund will apply if an Appliance has a valid warranty claim applicable to it.
12. To enquire about claiming under this warranty, please follow these steps:
  - (a) carefully check the operating instructions, user manual and the terms of this warranty;
  - (b) have the model and serial number of the Appliance available;
  - (c) have the proof of purchase (e.g. an invoice) available;
  - (d) telephone the numbers shown below.
13. You accept that if you make a warranty claim, Residentia Group and its ASR may exchange information in relation to you to enable Residentia Group to meet its obligations under this warranty.

---

### IMPORTANT

Before calling for service, please ensure that the steps in point 12 have been followed.

**The Australian Consumer Law requires the inclusion of the following statement with this warranty:** Our goods come with guarantees that cannot be excluded under the Australian Consumer Law. You are entitled to a replacement or refund for a major failure and for compensation for any other reasonably foreseeable loss or damage. You are also entitled to have the goods repaired or replaced if the goods fail to be of acceptable quality and the failure does not amount to a major failure.

---

### TELEPHONE CONTACTS

- ▶ Service: Please call 1300 11 HELP (4357)
- ▶ Spare Parts: Please call 1300 11 SPARE (7727)

# Esatto by airvolution

**Visit Us Online**  
[www.esatto.house](http://www.esatto.house)  
[www.airvolution.space](http://www.airvolution.space)

VERSION  
NUMBER

1.1



E2447