

Product:

60cm Fan-forced Oven

Model Code/s:

EO64M.1

**Esatto**  
**User Manual**  
Exactly what  
you need

Online:

[esatto.house](http://esatto.house)

**Residentia Group**

–  
Head Office.  
165 Barkly Ave  
Burnley VIC  
Australia 3121  
–  
ACN.  
600 546 656  
–  
Online.  
residentia.group

---

Congratulations on purchasing your new oven. The Esatto brand is proudly distributed within Australia by Residentia Group Pty Ltd.

Please refer to the warranty card at the rear of this manual for information regarding your product's parts and labour warranty, or visit us online at [www.residentia.group](http://www.residentia.group)

At Residentia Group, we are customer obsessed and our Support Team are there to ensure you get the most out of your appliance. Should you want to learn more about recommended cooking functions, the various features of your oven, and importantly taking care of your appliance when cleaning, our Support Team are here to help. You can use our online Support Centre at anytime by visiting <http://support.residentia.group.com.au>, or you can contact us via calling us on 1300 11 HELP (4357).

It is important that you read through the following use and care manual thoroughly to familiarise yourself with the installation and operation requirements of your appliance to ensure optimum performance.

Again, thank you for choosing an Esatto appliance and we look forward to being of service to you.

Kind Regards,  
The Residentia Team

---

Postage.  
PO Box 341, Mt Eliza  
Victoria Australia 3930

---

Telephone.  
1300 11 4357  
Email.  
[support@residentia.group.com.au](mailto:support@residentia.group.com.au)

---

**Contents**

---

**02**  
**Welcome**

---

**04**  
**Safety**  
**Instructions**

---

**06**  
**Your Esatto Oven**

---

**08**  
**Installation**  
**Instructions**

---

**08**  
**Operating**  
**Your Oven**

---

**13**  
**Cleaning &**  
**Maintenance**

---

**15**  
**Troubleshooting**  
**& Technical Data**

---

**16**  
**Warranty**  
**Information**

---

**17**  
**Purchase**  
**Details**

## Safety Instructions

This oven must only be installed by a suitably qualified and licenced person and in accordance with the instructions provided. Incorrect installation may cause harm to persons, damage property and void the product's warranty.

- IMPORTANT!** The power supply to the oven must be cut off before any adjustments or maintenance work is undertaken.
- WARNING** When using this product, basic precautions should always be taken including the following:
- This oven is designed for domestic household use and for the cooking of domestic foodstuffs.
- IMPORTANT!** Your built-in oven is an electrical appliance and as with any electrical appliance (particularly with electric heating elements), basic precautions must be followed in order to reduce the risk of fire, burns, electrical shocks and/or other serious injuries or even death.
- The appliance becomes hot during operation. Take care not to touch the hot parts inside the oven.
  - This appliance is not intended for use by persons (including children) with reduced physical, sensory or mental capabilities, or lack of experience and knowledge, unless they have been given supervision or instruction concerning use of the appliance by a person responsible for their safety.
  - Children should be supervised to ensure that they do not play with the appliance.
  - While in operation direct contact with the oven may cause burns!
  - Ensure that small items of household equipment, including connection leads, do not touch the hot oven as the insulation material of this equipment is usually not resistant to high temperatures.
  - Do not leave the oven unattended when cooking. Oils and fats may catch fire due to overheating.
  - Do not put pans on the opened door of the oven.
  - Do not use harsh cleaning agents or sharp metal objects to clean the door as they can scratch the surface, which could then result in the glass cracking.
  - Do not use the oven in the event of a technical fault. Any faults must be fixed by an appropriately qualified and authorised Residentia Group service agent. Refer to the warranty section at the rear of this user manual.
  - In the event of any incident caused by a technical fault, disconnect the power and report the fault to the service centre to be repaired.
  - The rules and provisions contained in this instruction manual should be strictly observed.
  - Do not allow anybody who is not familiar with the contents of this instruction manual to operate the oven.
  - The oven should not be cleaned using steam-cleaning equipment, as damage can occur to the inner electrical components.
  - The panels adjacent to the oven must be made of heat resistant material, or heat deflectors installed.
  - Cabinets with a veneer exterior must be assembled with glues, which can withstand temperature of up to 100 degrees Celsius.
  - Keep combustible materials such as: curtains, drapes, furniture, pillows, clothing, linens, bedding, paper, etc. at least 900mm from the front sides and rear of the oven.
  - Do not use this oven in areas where fuel, paint or other flammable liquids or their associated vapours may be present.

## Safety Instructions (Continued)

- To reduce the risk of fire, do not place or install this oven in areas where the ventilation or circulation ducts may become blocked.
- The oven's power cord must be connected to a properly grounded and protected, 220-240V electrical outlet. Always use ground fault protection where required by the electrical code.
- This oven is hard-wired and an extension cord should not be used.
- When transporting or storing the unit, keep it in a dry location, free from dust, excessive vibration or other factors, which may damage the unit.
- Do not operate any oven with a damaged cord or plug, after the heater malfunctions or has been dropped or damaged in any manner. Return the oven to an authorised Residentia Group service centre to be checked.
- If the supply cord is damaged, it must be replaced by a special cord or assembly available from Residentia Group or its authorised service agent.
- Use this oven only as described in this manual. Any other use not recommended by the manufacturer may cause fire, electric shock, or injury to persons.
- Never add cold water to food on a hot universal tray or baking tray or directly onto food in a hot oven. The steam created could cause serious burns or scalding and the sudden change in temperature can damage the enamel.
- Do not lift the oven by the handle.

### DECLARATION OF CONFORMITY

This appliance complies with the following Australian/European Directives:

- 2006/95/CE General regulations / Low tension
- 1935/2004/CE 90/128/EEC This appliance is suitable to come in contact with food
- 2004/108/CE Electromagnetic compatibility
- Low voltage – 73/23
- Safety standards – EN 60335-1, EN30-1-1, AS/NZS 3350-1,3350-2-6

The manufacturer declares that the oven is built using certified materials and requires the appliance to be installed in accordance with the standards currently in force. This oven should only be used by a trained person and for domestic purposes only.

### UNPACKING

During transportation, protective packaging was used to protect the appliance against any damage. After unpacking, please dispose of all elements of packaging in a way that will not cause damage to the environment. All materials used for packaging the appliance are environmentally friendly; they are 100% recyclable and are marked with the appropriate symbol.

- During unpacking, the packaging materials (polythene bags, polystyrene pieces, etc.) should be kept out of reach of children.

### DISPOSAL OF THE APPLIANCE

Old appliances should not simply be disposed of with normal household waste, but should be delivered to a collection and recycling centre for electric and electronic equipment. A symbol shown on the product, the instruction manual or the packaging shows that it is suitable for recycling.

Materials used inside the appliance are recyclable and are labelled with information concerning this. By recycling materials or other parts from used devices you are making a significant contribution to the protection of our environment.

Information on appropriate disposal centres for used devices can be provided by your local authority.

# Your Esatto Oven

## CONTROLS



## KEY

- 
- 1. Oven function selection knob
- 2. Temperature control knob
- 3. Minute Minder Timer

## Your Esatto Oven (Continued)

### OVEN COMPONENTS

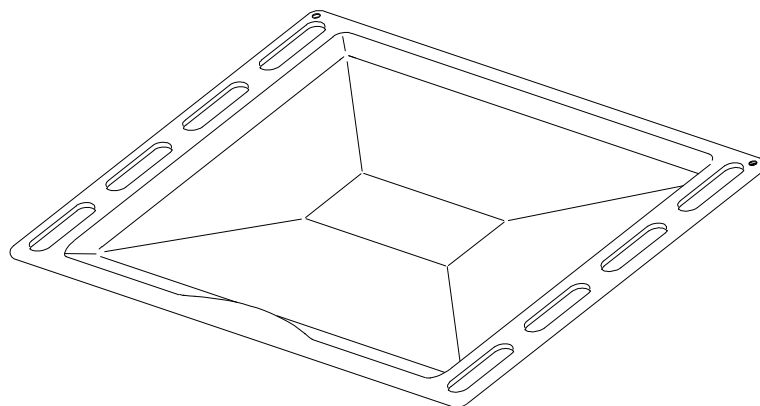

ROASTING TRAY

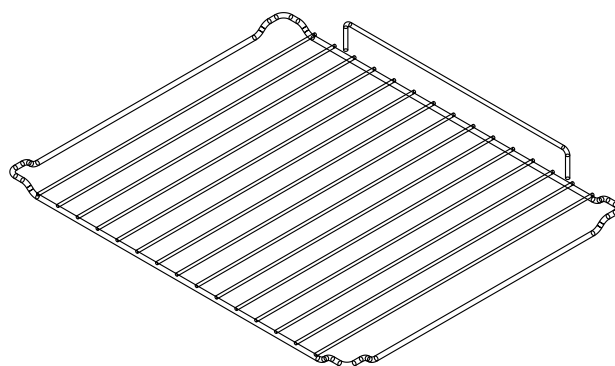

GRILLING RACK/SHELF

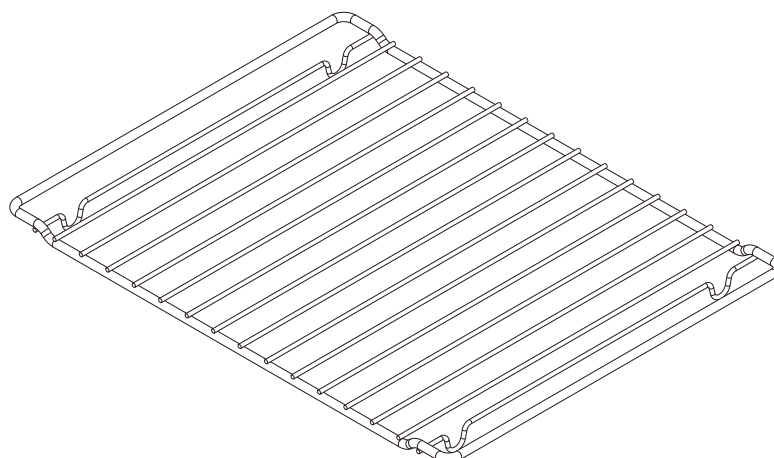

ROASTING TRAY INSERT

## Installation Instructions

It's important to carefully read the following installation instructions before beginning the installation of your oven.

**IMPORTANT!**

The connection of this oven must be carried out by a suitably qualified and licensed person, in accordance with the current versions of the following:

- AS/NZS 3000 Wiring Rules
- Electricity Safety Regulations 2010
- The installation instructions within this user manual

**Note:**

Ensure there is a grounded socket nearby (behind the unit). A dedicated power circuit is recommended for the unit but not required. Additional electrical appliances on the same circuit may exceed the current (amperage) rating for that circuit. If after the installation of your unit the circuit breaker trips or the fuse fails on a repeated basis then a dedicated circuit will likely be required.



## Installation Instructions (Continued)

### POSITIONING

The adjacent cabinetry and wall materials must be able to withstand a minimum temperature rise of 85°C above the ambient temperature of the room.

- The kitchen area should be dry and equipped with sufficient ventilation. When installing the oven, easy access to all control elements should be ensured.
- This is a built-in oven and has been designed to be housed within an oven cabinet. Coating or veneer used on cabinetry must be applied with a heat resistant adhesive (rated to 100°C). This prevents surface deformation or detachment of the coating. In the case of vinyl wrap kitchens, it is strongly recommended to have heat deflectors installed on either side of the oven cabinet.
- Your oven cabinet should be made to suit the following dimensions and can be either a tall or underbench cabinet to suit your kitchen design.
- Make sure that the electrical circuit is disconnected or fuse removed, then connect the oven into the mains supply.

### IMPORTANT!

As this appliance is hard-wired, the installation/connection should only be completed by a licensed electrician.

- Insert the oven completely into the oven cabinet and use the four screws supplied to fix the oven into place (refer to the diagram below).

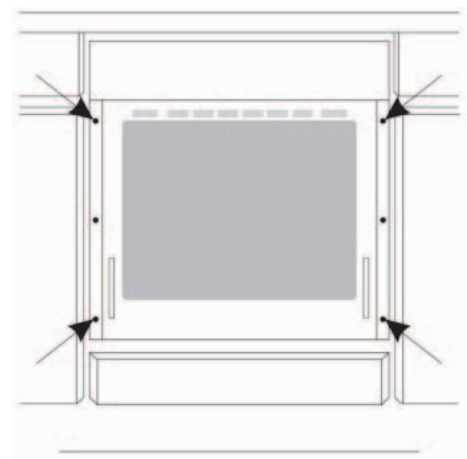
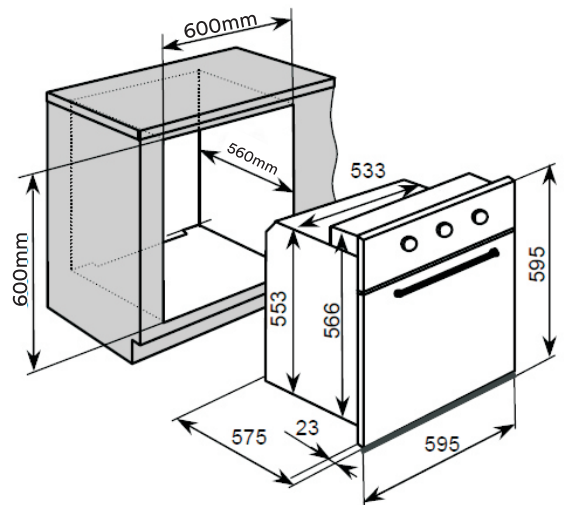
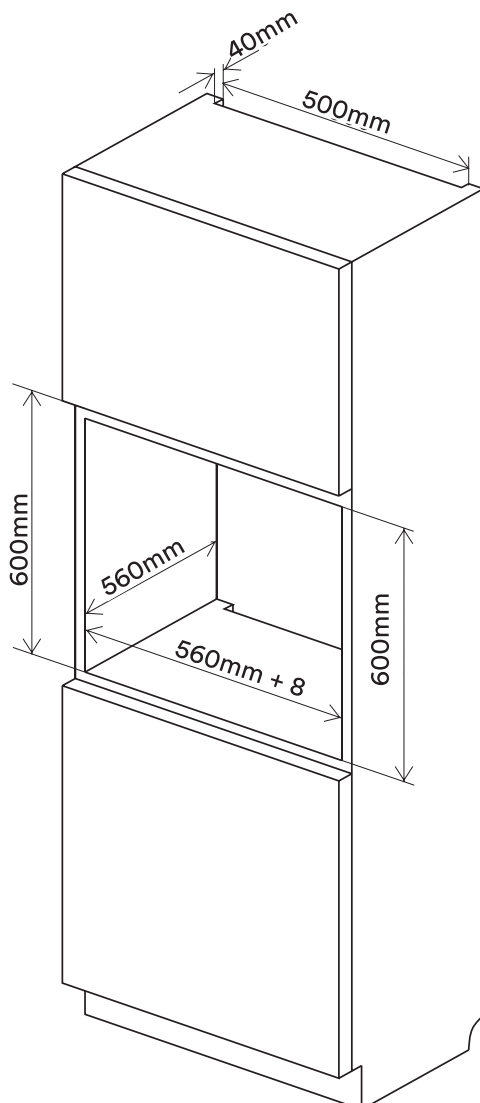

# Installation Instructions (Continued)

## FITTING GUIDELINES

**WARNING!**

The installation must be carried out by a suitably qualified and licensed person and in accordance with the current standards.



The oven is manufactured to work with three-phase alternating current (220V-240V/50Hz). The connection diagram is also found on the cover of the connection box.

**Remember:**



The connection wire should match the connection type and the power rating of the oven.



The connection cable must be secured in a strain-relief clamp.

**WARNING!**

Remember to connect the safety circuit to the connection box terminal marked with  $\perp$ . The electricity supply for the oven must have a safety switch which enables the power to be cut off in the case of an emergency. The distance between the working contacts of the safety switch must be at least 3mm.

Before connecting the oven to the power supply it is important to read the information on the data plate and the connection diagram.

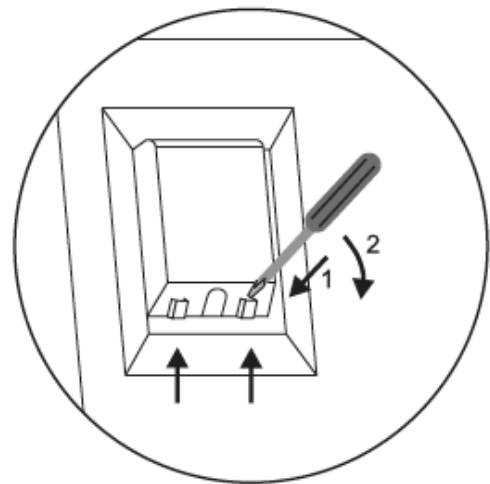
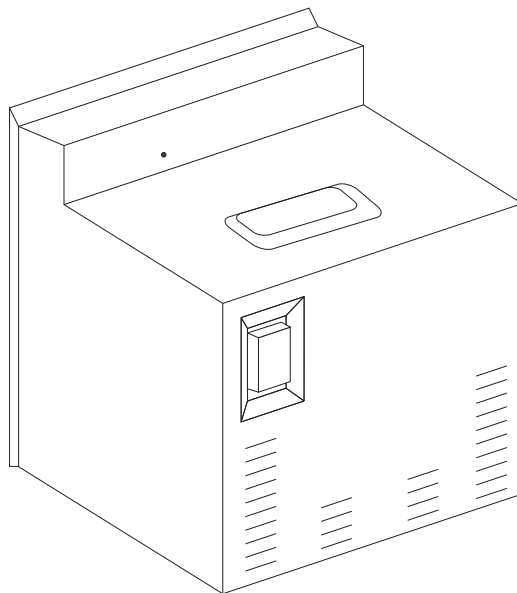

### CONNECTION DIAGRAM

**Caution! Voltage of heating elements 220V~240V**

Caution! In the event of any connection the safety wire must be connected to the  $\perp$  PE terminal

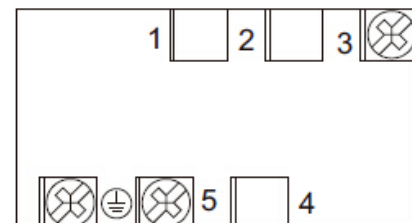

For 220V~240V earthed one phase connect on:L (Brown wire) connect to 3 and N (blue wire)connect to 5, safety wire (Yellowgreen) connectto  $\perp$  PE terminal

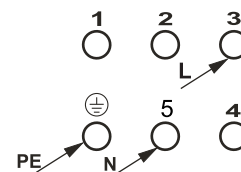

## Operating your Oven

### BEFORE THE OVEN'S FIRST USE

Remove all packaging and clean the interior of the oven.

- Take out and wash the oven fittings with warm soapy water.
- Switch on any ventilation within the room (such as a rangehood), or open any windows.
- Heat the oven to a temperature of 250°C for approximately 30-45 minutes.

**Note:** There may be strong odour during the first use, which is the burning off of any chemical residues from its construction. This is normal for all ovens.

**IMPORTANT!** The inside of the oven should only be washed with warm water and a small amount of washing up liquid.

### OVEN FUNCTIONS & OPERATION





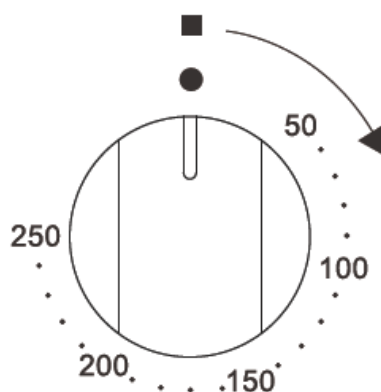
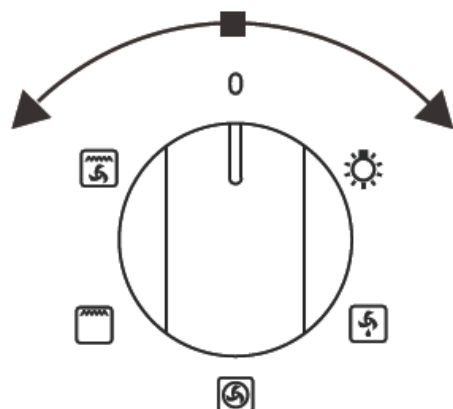





**IMPORTANT!** In order for the oven to operate, you must:

- Select the required conditions of the oven.  
I.e. its temperature and a mode of heating.
- Set the knobs to the required positions, turning it to the right (clockwise).
- Your oven will begin to operate.



## Operating your Oven (Continued)

### OVEN FUNCTIONS

Model:	Functions:	
EO64M.1	    	
Function Symbol:	Function Type:	Function Description:
	Oven Light	By selecting this option, the lighting inside the oven is switched on. Note: The oven will not heat on this setting.
	Defrost	This function allows all frozen foods to be rapidly and delicately thawed thanks to the internal fan.
	Central element and fan	This function enables homogenous distribution of the heat inside the oven, making it possible to cook several items of food at the same time.
	Grill element	This function operates the top grill element. Important! You should only ever use the grill with the oven door shut.
	Grill and fan assist	This function operates the grill element with fan to distribute the heat evenly. Excellent combination for cooking chicken and a variety of roasts, sealing the juices in.

### FAST START FEATURE

Your Esatto oven is equipped with a fast start function which can be used to bring your oven up to 150°C in approximately 4 minutes.

To use this feature:

- Set the oven function knob to the position of “Fan assisted Bottom & Central elements”.
- Set the temperature knob to 150°C (or lower if desired).
- Once the oven is at temperature, the “Oven Heating” indicator (Indicator D) will switch off.

### USE OF THE GRILL

Your Esatto oven grills through the use of infrared rays emitted by the incandescent grill heater.

**IMPORTANT!** You should always use the grill function with the door shut. When the grill is in use with the oven door open, accessible parts can become hot and damage can be done to the controls.

In order to use the grill:

- Set the oven function knob to one of the grill functions.
- Heat the oven for approximately 4-5 minutes.
- Insert a tray with your dish onto the appropriate cooking shelf.

**Note:** The grill function can be used up to a maximum of 250°C, whilst the “Grill and fan assist” function can be used at a maximum of 200°C.

## Cleaning & Maintenance

By ensuring proper cleaning and maintenance of your Esatto oven, you can ensure that it will have a long and fault free operation.

### WARNING!

Do not start cleaning the oven until it has completely cooled.

- Typically you should only ever need to clean your oven with warm soapy water, or light cleaning products to assist with the removal of fat or oil emulsions.
- Your oven should be cleaned after every use and you can use the “Light” function to assist with visibility.
- After cleaning your oven chamber, you should wipe it dry.

### CLEANING THE GLASS

- Glass surfaces on the door and control panel should be cleaned immediately after soiling, using a damp cloth.
- Oven cleaners may be used to remove stubborn stains and built-up residues.
- Avoid the use of harsh abrasive cleaners and sharp metal scrapers as they can scratch or damage the surface.

### CLEANING THE STAINLESS STEEL

All grades of stainless steel can stain or discolour and you must regularly ensure it's kept clean using the following procedures:

- Start by using clean, warm soapy water. For stubborn stains or discolouration, you can try stainless steel cleaners available from the supermarket.
- Be careful when cleaning the stainless steel, as there may be sharp edges.
- DO NOT use abrasive or harsh solvent cleaners.

### CLEANING THE OVEN/GRILL

- Always keep the internal of the oven clean, ensuring that fats and oils don't accumulate around the elements or fan.
- Always keep the oven dish, baking trays and grill dish inserts clean as any deposits may catch fire or smoke.
- Always wrap your meats in aluminium foil or use a covered oven-roasting dish to minimise required cleaning.

### DOOR REMOVAL

In order to obtain easier access to the oven chamber for cleaning, it is possible to remove the door.

To do this:

- Tilt the safety catch part of the hinge upwards.
- Close the door lightly, lift and pull it out towards you.
- In order to fit the door back on to the oven, do the reverse.

When fitting, ensure that the notch of the hinge is correctly placed on the protrusion of the hinge holder. After the door is fitted to the oven, the safety catch should be carefully lowered down again. If the safety catch is not set it may cause damage to the hinge when closing the door.

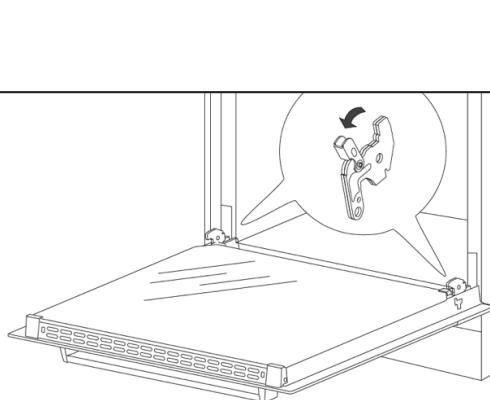

## Cleaning & Maintenance (Continued)

### REMOVAL OF THE INTERNAL GLASS PANEL

Glass door has two plastic fixed blocks. Use a slotted screwdriver to insert into the hole of the plastic fixed block and gently pry it. Remove the fixed block and the top ends of the plastic ventilation grid. The inner glass pulled out from beneath plastic fixed block. After cleaning, the inner glass insert the following plastic fixed block, then install the above plastic mounting block.

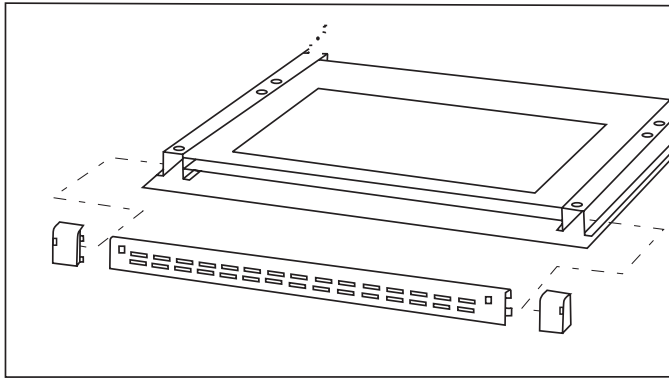

### REPLACEMENT OF THE LIGHT GLOBE

#### WARNING!

In order to avoid the possibility of an electric shock, ensure that the appliance is switched off at the isolator switch, before removing the light globe.

- Set all control knobs to the off position and switch the oven off at the isolator switch.
- Unscrew the Light Globe cover. Unscrew the blown light globe.
- Replace the globe with a new oven globe with the following parameters:
  - Voltage: 230v
  - Power: 25W
  - E14 Oven globe
- Screw the Light Globe cover back into place.

## Troubleshooting & Technical Data

### OPERATION IN CASE OF EMERGENCY

In the event of an emergency you should:

- Switch off all oven controls (i.e. Cooking Function and Temperature)
- Switch the oven off at the isolation switch or at the fuse box.
- Call the Residentia Support Team on 1300 11 HELP (4357).

Some minor faults can be fixed by referring to the instructions given in the Troubleshooting section below. There is also a self-help section online at <http://www.residentiagroup.com.au>.

### TROUBLESHOOTING

Fault	Possible Cause	Solution
The oven isn't turning on.	Break in power supply.	▶ Check the household fuse box for any blown fuses and replace as necessary. Also ensure that a safety switch hasn't tripped.
The oven light isn't working.	The light globe is loose or has blown.	▶ When completely cool and switched off, remove the globe cover and ensure that the globe is tight. If blown, refer to the Cleaning and Maintenance section on how to replace a globe.
The oven is burning the top of my dish whilst the underside is under-done.	Not enough heat from the bottom.	▶ Try using the Conventional cooking functions. ▶ Try lowering the temperature. ▶ Try using a lower shelf position.
The oven is burning the underside of my dish whilst the top is under-done.	Excessive heat from the bottom.	▶ Try using the Conventional cooking functions. ▶ Try lowering the temperature. ▶ Try using a higher shelf position.
The oven is burning the outside of my dish whilst the inside is under-done.	Temperature is set too high.	▶ Lower the temperature and increase the cooking duration.
The outside of my dish is too dry even though it looks cooked.	Temperature is set too low.	▶ Increase the temperature and decrease the cooking duration.

### TECHNICAL DATA

Electrical details	Rated Voltage:	220 - 240V, 50Hz
	Power rating:	Maximum 2.0kW
Oven details	Dimensions (H,W,D cm):	59.5cm, 59.5cm, 57.5cm
	Gross Capacity	65 litres
	Weight:	~30kg



# Warranty Information

## WARRANTY TERMS & CONDITIONS COOKING APPLIANCES (BUILT-IN OVENS, COOKTOPS)

This document sets out the terms and conditions of the product warranties for Residentia Group Appliances. It is an important document. Please keep it with your proof of purchase documents in a safe place for future reference should you require service for your Appliance.

### 1. IN THIS WARRANTY

- (a) 'acceptable quality' as referred to in clause 10 of this warranty has the same meaning referred to in the ACL;
  - (b) 'ACL' means Trade Practices Amendment (Australian Consumer Law) Act (No.2) 2010;
  - (c) 'Appliance' means any Residentia Group product purchased by you accompanied by this document;
  - (d) 'ASR' means Residentia Group authorised service representative;
  - (e) 'Residentia Group' means Residentia Group Pty Ltd of 165 Barkly Ave, Burnley VIC 3121, ACN 600 546 656 in respect of Appliances purchased in Australia;
  - (f) 'major failure' as referred to in clause 10 of this warranty has the same meaning referred to in the ACL and includes a situation when an Appliance cannot be repaired or it is uneconomic for Residentia Group, at its discretion, to repair an Appliance during the Warranty Period;
  - (g) 'Warranty Period' means:
    - (i) where the Appliance is used for personal, domestic or household use (i.e. normal single family use) as set out in the instruction manual, the Appliance is warranted against manufacturing defects for 24 months, following the date of original purchase of the Appliance;
  - (h) 'you' means the purchaser of the Appliance not having purchased the Appliance for re-sale, and 'your' has a corresponding meaning.
2. This warranty only applies to Appliances purchased and used in Australia and is in addition to (and does not exclude, restrict, or modify in any way) any non-excludable statutory warranties in Australia.
  3. During the Warranty Period Residentia Group or its ASR will, at no extra charge if your Appliance is readily accessible for service, without special equipment and subject to these terms and conditions, repair or replace any parts which it considers to be defective. Residentia Group or its ASR may use remanufactured parts to repair your Appliance. You agree that any replaced Appliances or parts become the property of Residentia Group. This warranty does not apply to light globes, batteries, filters or similar perishable parts.
  4. Parts and Appliances not supplied by Residentia Group are not covered by this warranty.

5. You will bear the cost of transportation, travel and delivery of the Appliance to and from Residentia Group or its ASR. If you reside outside of the service area, you will bear the cost of:
  - (a) travel of an authorised representative;
  - (b) transportation and delivery of the Appliance to and from Residentia Group or its ASR, in all instances, unless the Appliance is transported by Residentia Group or its ASR, the Appliance is transported at the owner's cost and risk while in transit to and from Residentia Group or its ASR.
6. Proof of purchase is required before you can make a claim under this warranty.
7. You may not make a claim under this warranty unless the defect claimed is due to faulty or defective parts or workmanship. Residentia Group is not liable in the following situations (which are not exhaustive):
  - (a) the Appliance is damaged by:
    - (i) accident
    - (ii) misuse or abuse, including failure to properly maintain or service
    - (iii) normal wear and tear
    - (iv) power surges, electrical storm damage or incorrect power supply
    - (v) incomplete or improper installation
    - (vi) incorrect, improper or inappropriate operation
    - (vii) insect or vermin infestation
    - (viii) failure to comply with any additional instructions supplied with the Appliance;
  - (b) the Appliance is modified without authority from Residentia Group in writing;
  - (c) the Appliance's serial number or warranty seal has been removed or defaced;
  - (d) the Appliance was serviced or repaired by anyone other than Residentia Group, an authorised repairer or ASR.
8. This warranty, the contract to which it relates and the relationship between you and Residentia Group are governed by the law applicable where the Appliance was purchased.
9. To the extent permitted by law, Residentia Group excludes all warranties and liabilities (other than as contained in this document) including liability for any loss or damage whether direct or indirect arising from your purchase, use or non use of the Appliance.





- 10.** For Appliances and services provided by Residentia Group in Australia, the Appliances come with a guarantee by Residentia Group that cannot be excluded under the Australian Consumer Law. You are entitled to a replacement or refund for a major failure and for compensation for any other reasonably foreseeable loss or damage. You are also entitled to have the Appliance repaired or replaced if the Appliance fails to be of acceptable quality and the failure does not amount to a major failure. The benefits to you given by this warranty are in addition to your other rights and remedies under a law in relation to the Appliances or services to which the warranty relates.
- 11.** At all times during the Warranty Period, Residentia Group shall, at its discretion, determine whether repair, replacement or refund will apply if an Appliance has a valid warranty claim applicable to it.
- 12.** To enquire about claiming under this warranty, please follow these steps:
- carefully check the operating instructions, user manual and the terms of this warranty;
  - have the model and serial number of the Appliance available;
  - have the proof of purchase (e.g. an invoice) available;
  - telephone the numbers shown below.
- 13.** You accept that if you make a warranty claim, Residentia Group and its ASR may exchange information in relation to you to enable Residentia Group to meet its obligations under this warranty.

**IMPORTANT**

Before calling for service, please ensure that the steps in point 12 have been followed.

*Telephone Contact*

- Service: Please call 1300 11 HELP (4357)

**The Australian Consumer Law requires the inclusion of the following statement with this warranty:**

Our goods come with guarantees that cannot be excluded under the Australian Consumer Law. You are entitled to a replacement or refund for a major failure and for compensation for any other reasonably foreseeable loss or damage. You are also entitled to have the goods repaired or replaced if the goods fail to be of acceptable quality and the failure does not amount to a major failure.

## Purchase Details

For future reference, please record the following information which can be found on the rating plate (located inside the door of your oven) and the date of purchase which can be found on your sales invoice.

**STORE DETAILS**

STORE NAME | \_\_\_\_\_

ADDRESS | \_\_\_\_\_

TELEPHONE | \_\_\_\_\_

PURCHASE DATE | \_\_\_\_\_

**PRODUCT DETAILS**

MODEL NO. | \_\_\_\_\_

SERIAL NO. | \_\_\_\_\_





# Esatto Appliances Exactly what you need



E2447

**A Residentia Group Initiative**

[WWW.RESIDENTIA.GROUP](http://WWW.RESIDENTIA.GROUP)